

COMMERCIAL R32







COMMERCIAL R32

MONOSPLIT R32			
SERIES	3,5 kW	5,0 kW	7,1 kW
CASSETTE 620	 AB35S2SC2FA/ AB35S2SC2FA-1	 AB50S2SC2FA/ AB50S2SC2FA-1	
CASSETTE ROUND FLOW			 AB71S2SG1FA
CEILING FLOOR	 AC35S2SG1FA	 AC50S2SG1FA	 AC71S2SG1FA
SLIM DUCT LOW PRESSURE	 AD35S2SS1FA/ AD35S2SS1FA(H)	 AD50S2SS1FA/ AD50S2SS1FA(H)	 AD71S2SS1FA/ AD71S2SS1FA(H)
DUCTED MEDIUM PRESSURE	 AD35S2SM3FA/ AD35S2SM3FA(H)	 AD50S2SM3FA/ AD50S2SM3FA(H)	 AD71S2SM3FA/ AD50S2SM3FA(H)
DUCTED HIGH PRESSURE			
CABINET			
WALL MOUNTED			
OUTDOOR UNITS MONOSPLIT R32			
SINGLE-PHASE	1U35S2SM1FA	1U50S2S J2FA	1U71S2SR2FA
THREE-PHASE			

The expressed kW/Btu is for cooling classification. For exact values, see the technical data tables of the individual models.

COMMERCIAL R32

10,5 kW	12,5 kW	14,0 kW	16,0 kW
 ABH105H1ERG	 ABH125K1ERG	 ABH140K1ERG	 ABH160K1ERG
 AC105S2SH1FA	 AC125S2SK1FA	 AC140S2SK1FA	 AC160S2SK1FA
 AD105S2SM3FA/ AD105S2SM3FA(H)	 AD125S2SM3FA	 AD140S2SM3FA	 AD160S2SM3FA
	 ADH125H1ERG	 ADH140H1ERG	
 AS105S2SF2FA-2		 AP140S2SK1FA/ AP140S2SK1FA(H)	
 1U105S2SS2FA	 1U125S2SN2FA	 1U140S2SN1FA/1U140S2SP2FA	 1U160S2SP1FB
1U105S2SS1FB	1U125S2SN2FB	1U140S2SN1FB/1U140S2SP2FB	1U160S2SP1FB

The expressed kW is for cooling classification. For exact values, see the technical data tables of the individual models.

Commercial R32 CASSETTE 620



AB35 - AB50



1U35

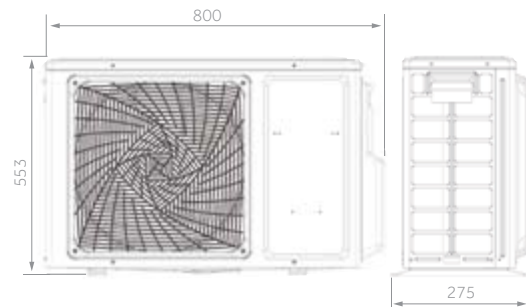
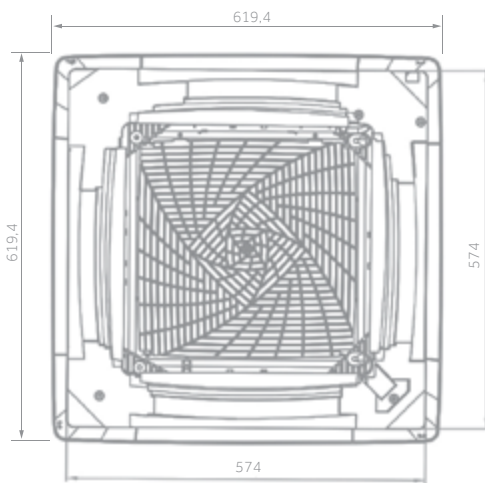

1U50

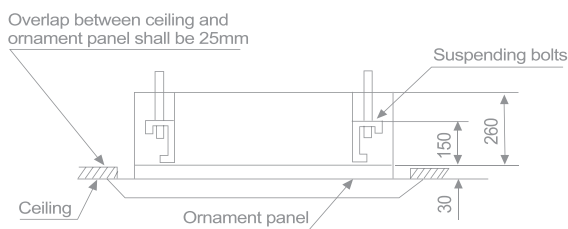
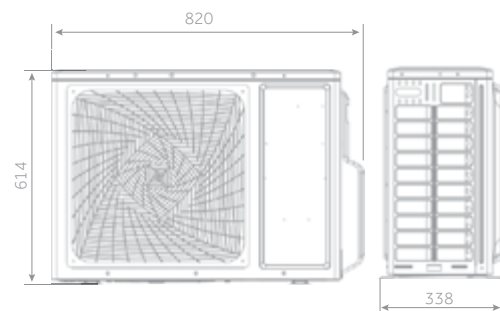

3,5 kW

5,0 kW

Commercial R32 CASSETTE 620

Haier

2,5 kW

3,5 kW

OPTIONAL CONTROL

COMMERCIAL R32



Silence



4way Independent



Wi-Fi Optional



Fresh Air

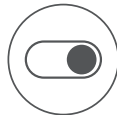

On-Off Card

- Low noise level
- Wi-Fi control (OPTIONAL)
- 'Fresh air' knockout is incorporated in the chassis to allow fresh air introduction of up to 20% of nominal unit air flow without compromising the cooling capacity. More than 20% of the air conditioner's thermal cooling capacity is penalise.
- On-Off card

Indoor Unit	Model		AB35S2SC2FA	AB50S2SC2FA
Outdoor Unit	Model		1U35S2SM1FA	1U50S2S J2FA
Performance data				
Output power - COOLING	nom (min-max)	kW	3,50 (0,90-4,50)	5,00 (1,80-5,80)
Output power - HEATING	nom (min-max)	kW	4,00 (1,00-4,80)	5,50 (2,00-6,50)
Absorbed power - COOLING	nom (min-max)	kW	1,06 (0,28-1,80)	1,53 (0,55-2,00)
Absorbed power - HEATING	nom (min-max)	kW	1,08 (0,28-1,80)	1,52 (0,60-2,00)
Energy class	EER	W/W	3,31	3,26
	COP	W/W	3,71	3,42
COOLING Pdesign	35 °C	kW	3,50	5,00
HEATING Pdesign	(-10 °C)	kW	3,00	4,00
Energy class	SEER		6,10 (A++)	6,10 (A++)
	SCOP		3,80 (A)	3,80 (A)
Annual Energy Consumption - COOLING		kWh/a	222	363
Annual Energy Consumption - HEATING		kWh/a	1427	1932
Indoor Unit				
Power supply		Ph/V/Hz	1/220-240/50/60	1/220-240/50/60
Treated air volume	(H/M/L/Q)	m ³ /h	620/520/450/350	700/620/500/400
High sound power		dB	52	55
Sound pressure		dB(A)	36/33/30/27	42/37/35/32
Net dimensions	WxDxH	mm	570x570x260	570x570x260
Packaging dimensions	WxDxH	mm	718x680x380	718x680x380
Net/gross weight		kg	18,5/22,0	19,0/22,0
Panel	Model		PB-620KB	PB-620KB
Panel Net dimensions			620x620x60	620x620x60
Panel Packaging dimensions			660x660x115	660x660x115
Panel Net/gross weight			2,8/4,5	2,8/4,5
Outdoor Unit				
Power supply		Ph/V/Hz	1/220-240/50	1/220-240/50
Power cable		N x mm ²	3 x 1,5	3 x 1,5
Interconnection cable		N x mm ²	4 x 1,0	4 x 1,0
Sound power	H	dB	61	63
Sound pressure	H	dB(A)	48	51
Running current cooling/heating	Max	A	8,0	9,5
Starting current cooling/heating	Max	A	2,0	2,0
Net dimensions	WxDxH	mm	800x275x553	820x338x614
Packaging dimensions	WxDxH	mm	908x405x625	993x413x685
Net/gross weight		kg	30,0/32,9	37,8/41,5
Compressor type			Rotary inverter	Twin rotary inverter
Installation data				
Refrigerant			R32	R32
Liquid pipe	∅	mm (inch)	6,35 (1/4)	6,35 (1/4)
Gas pipe	∅	mm (inch)	9,52 (3/8)	12,70 (1/2)
Standard pipe length without refrigerant charge		m	7	7
Maximum pipe length		m	15	25
Maximum IU - OU elevation		m	10	15
Refrigerant charge in the factory		kg	0,78	0,95
Refrigerant charge in the factory		TCO _{2eq}	0,53	0,64
Additional ref. charge over std length		g/m	20	20
Outdoor operating limits - COOLING	min-max	°C		-10-46
Outdoor operating limits - HEATING	min-max	°C		-15-24

Commercial R32 CASSETTE 620



AB35 - AB50

1U35

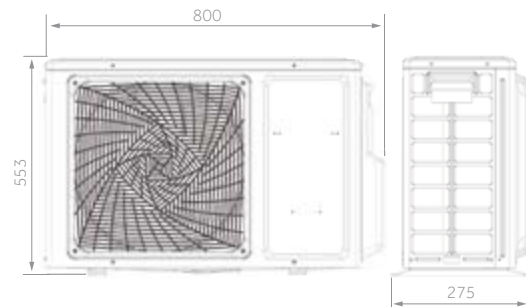
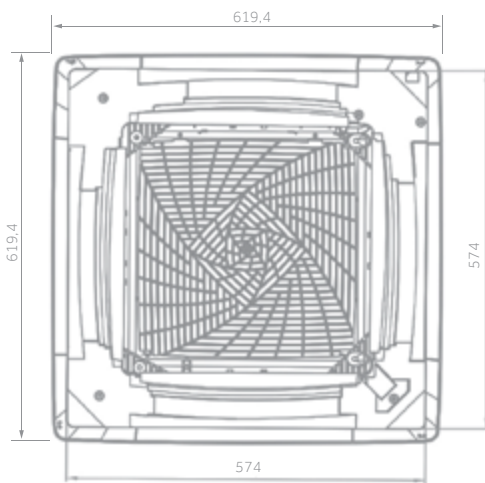

1U50

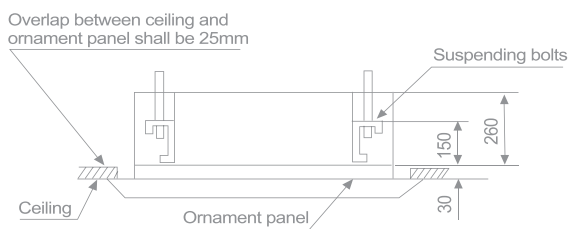
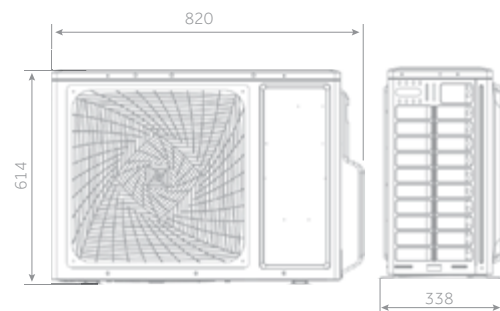

3,5 kW

5,0 kW

Commercial R32 CASSETTE 620 **NEW**

Haier

2,5 kW

3,5 kW

OPTIONAL CONTROL

COMMERCIAL R32



NEW



Silence



4way Independent



Wi-Fi control
integrated



Fresh Air

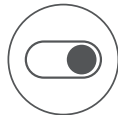

On-Off Card

- Low noise level
- Wi-Fi control integrated
- 'Fresh air' knockout is incorporated in the chassis to allow fresh air introduction of up to 20% of nominal unit air flow without compromising the cooling capacity. More than 20% of the air conditioner's thermal cooling capacity is penalise.
- On-Off card

Indoor Unit		Model	AB35S2SC2FA-1	AB50S2SC2FA-1
Outdoor Unit		Model	1U35S2SM1FA-2	1U50S2SJ2FA
Performance data				
Output power - COOLING	nom (min-max)	kW	3,50 (0,90-4,50)	5,00 (1,80-5,80)
Output power - HEATING	nom (min-max)	kW	4,00 (1,00-4,80)	5,50 (2,00-6,50)
Absorbed power - COOLING	nom (min-max)	kW	1,06 (0,28-1,80)	1,53 (0,55-2,00)
Absorbed power - HEATING	nom (min-max)	kW	1,08 (0,28-1,80)	1,52 (0,60-2,00)
Energy class	EER	W/W	3,31	3,26
	COP	W/W	3,71	3,42
COOLING Pdesign	35 °C	kW	3,50	5,00
HEATING Pdesign	(-10 °C)	kW	3,00	4,00
Energy class	SEER		6,10 (A++)	6,10 (A++)
	SCOP		3,80 (A)	3,80 (A)
Annual Energy Consumption - COOLING		kWh/a	222	363
Annual Energy Consumption - HEATING		kWh/a	1427	1932
Indoor Unit				
Power supply		Ph/V/Hz	1/220-240/50/60	1/220-240/50/60
Treated air volume	(H/M/L/Q)	m ³ /h	620/520/450/350	700/620/500/400
High sound power		dB	52	55
Sound pressure		dB(A)	36/33/30/27	42/37/35/32
Net dimensions	WxDxH	mm	570x570x260	570x570x260
Packaging dimensions	WxDxH	mm	718x680x380	718x680x380
Net/gross weight		kg	18,5/22,0	19,0/22,0
Panel	Model		PB-620KB	PB-620KB
Net dimensions			620x620x60	620x620x60
Packaging dimensions			660x660x115	660x660x115
Net weight			2,8/4,5	2,8/4,5
Outdoor Unit				
Power supply		Ph/V/Hz	1/220-240/50	1/220-240/50
Power cable		N x mm ²	3 x 1,5	3 x 1,5
Interconnection cable		N x mm ²	4 x 1,0	4 x 1,0
Sound power	H	dB	61	63
Sound pressure	H	dB(A)	48	51
Running current cooling/heating	Max	A	8,0	9,5
Starting current cooling/heating	Max	A	2,0	2,0
Net dimensions	WxDxH	mm	800x275x553	820x338x614
Packaging dimensions	WxDxH	mm	908x405x625	993x413x685
Net/gross weight		kg	30,0/32,9	37,8/41,5
Compressor type			Rotary inverter	Twin rotary inverter
Installation data				
Refrigerant			R32	R32
Liquid pipe	Ø	mm (inch)	6,35 (1/4)	6,35 (1/4)
Gas pipe	Ø	mm (inch)	9,52 (3/8)	12,70 (1/2)
Standard pipe length without refrigerant charge		m	7	7
Maximum pipe length		m	15	25
Maximum IU - OU elevation		m	10	15
Refrigerant charge in the factory		kg	0,78	0,95
Refrigerant charge in the factory		TCO ₂ eq	0,53	0,64
Additional ref. charge over std length		g/m	20	20
Outdoor operating limits - COOLING	min-max	°C		-10-46
Outdoor operating limits - HEATING	min-max	°C		-15-24

The data in this catalogue is purely indicative as the data may vary. Please be advised to check the accuracy of the data with the supplier before purchasing products.

Commercial R32
ROUND FLOW CASSETTE



Commercial R32 ROUND FLOW CASSETTE

Haier

COMMERCIAL R32

INTELLIGENT SENSOR optional

The sensor detects the number, position and movement of people to provide optimal temperature control with direct and indirect flows.

This technology reduces energy consumption by about 27%, without sacrificing comfort.

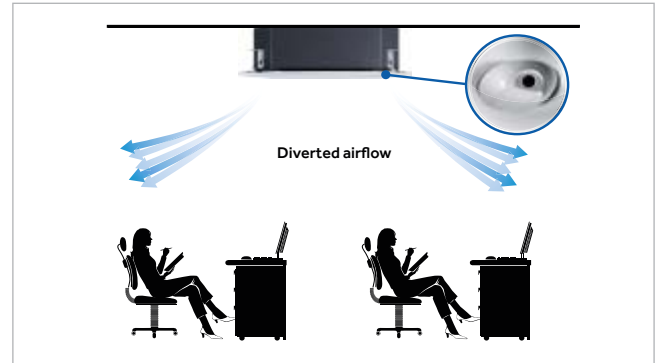
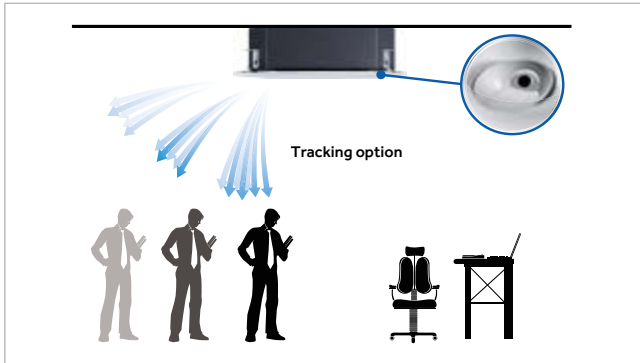
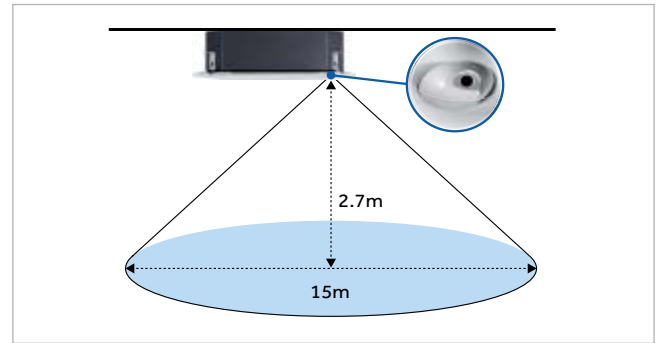

360-DEGREE FLOW

Thanks to an 8 way flow of air, it is possible to ensure a 360-degree airflow without any blind spots.

NEW DESIGN +23% AIRFLOW

The increased surface area of the new grill ensures a greater distribution of air (+23%) compared to traditional models.



CONDENSATE DRAIN

The ducted units include the condensation drain pump as standard, which guarantees a maximum prevalence of 1000 mm measured from the base of the machine.

There is the possibility of performing condensate drain by gravity (reversible on both sides).

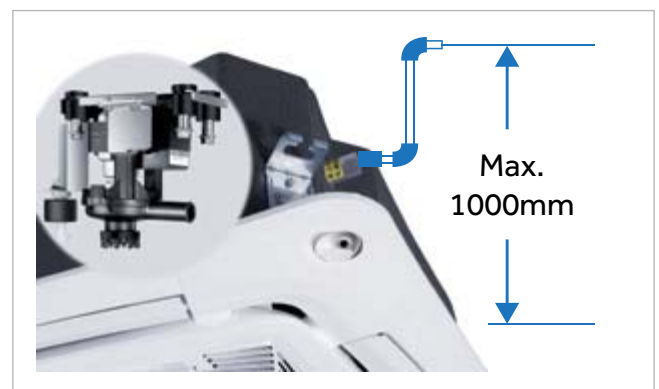

FRESH AIR

Air exchange allows introduction of clean air into the ambient.

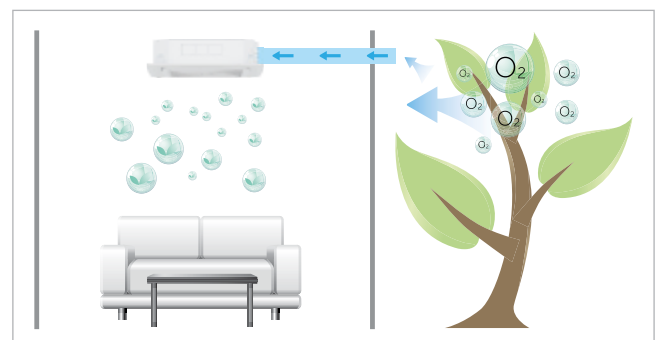

The data in this catalogue is purely indicative as the data may vary. Please be advised to check the accuracy of the data with the supplier before purchasing products.

Commercial R32 ROUND FLOW CASSETTE



AB71 - ABH105 - ABH125

1U71

1U105

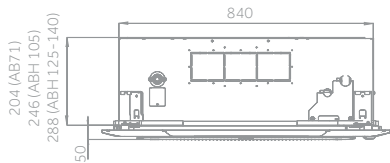
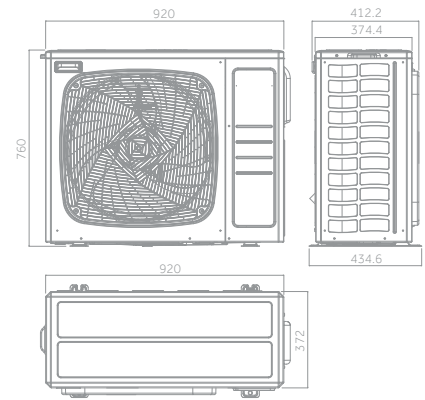
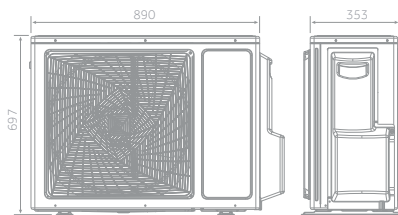
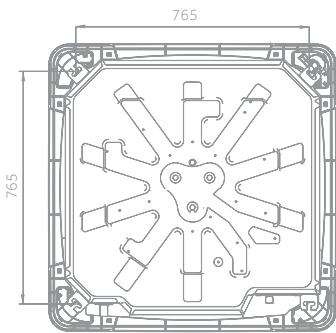

1U125

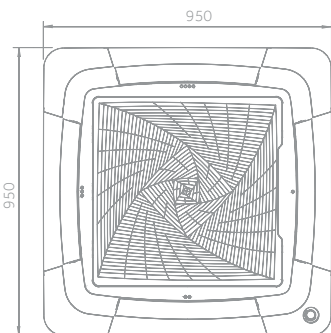
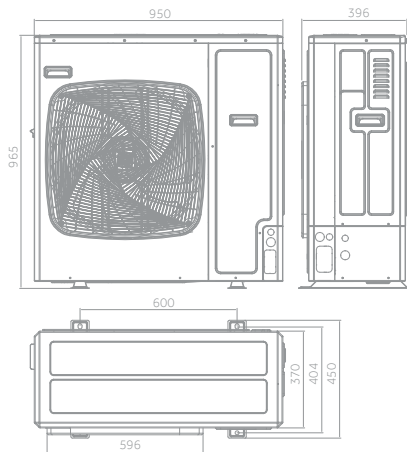

7,1 kW



10,5 kW



12,5 kW

Commercial R32 ROUND FLOW CASSETTE

Haier

7,1 kW

10,5 kW

12,5 kW

OPTIONAL CONTROL



Silence



8way Independent



Wi-Fi Optional



Fresh Air



- Low noise level
- Wi-Fi control (OPTIONAL)
- 'Fresh air' knockout is incorporated in the chassis to allow fresh air introduction of up to 20% of nominal unit air flow without compromising the cooling capacity. More than 20% of the air conditioner's thermal cooling capacity is penalise.
- Sensor (OPTIONAL) detects real-time air conditions and movement of people

Indoor Unit	Model		AB71S2SG1FA	ABH105H1ERG	ABH105H1ERG	ABH125K1ERG	ABH125K1ERG
Outdoor Unit	Model		1U71S2SR2FA	1U105S2SS2FA	1U105S2SS1FB	1U125S2SN2FA	1U125S2SN2FB
Performance data							
Output power - COOLING	nom (min-max)	kW	7,10 (2,00-7,30)	9,20 (2,50-10,00)	9,20 (2,50-10,00)	12,30 (3,00-13,00)	12,40 (3,00-13,00)
Output power - HEATING	nom (min-max)	kW	8,00 (2,50-8,00)	10,10 (3,00-10,50)	10,50 (3,00-11,00)	12,70 (3,50-13,50)	12,80 (3,50-13,50)
Absorbed power - COOLING	nom (min-max)	kW	2,20 (0,50-2,60)	3,12 (0,50-4,00)	3,25 (0,50-4,00)	4,84 (1,00-6,00)	4,81 (1,00-6,00)
Absorbed power - HEATING	nom (min-max)	kW	1,91 (0,50-2,60)	2,91 (0,50-4,00)	3,10 (0,50-4,00)	4,44 (1,00-6,00)	4,41 (1,00-6,00)
Energy class	EER	W/W	3,23	3,00	3,00	2,54	2,58
	COP	W/W	3,72	3,50	3,50	2,86	2,93
COOLING Pdesign	35 °C	kW	7,10	9,20	9,20	12,30	12,40
HEATING Pdesign	(-10 °C)	kW	5,00	7,00	6,00	8,30	8,30
Energy class	SEER		6,10 (A++)	5,90 (A+)	5,90 (A+)	5,68 (A+)	5,71 (A+)
	SCOP		3,80 (A)	3,80 (A)	3,91 (A)	3,93 (A)	3,96 (A)
Annual Energy Consumption - COOLING		kWh/a	406	555	555	740	736
Annual Energy Consumption - HEATING		kWh/a	1831	2780	2136	3032	3003
Indoor Unit							
Power supply		Ph/V/Hz	1/220-240/50/60	1/220-240/50/60	1/220-240/50/60	1/220-240/50/60	1/220-240/50/60
Treated air volume	(H/M/L/Q)	m ³ /h	1260/1070/820/680	1680/1530/1320/1190	1680/1530/1320/1190	1950/1600/1440/1200	1950/1600/1440/1200
High sound power		dB	55	62	63	64	64
Sound pressure		dB(A)	42/40/38/35	45/42/38/34	45/42/38/34	47/44/38/34	47/44/38/34
Net dimensions	WxDxH	mm	840x840x204	840x840x246	840x840x246	840x840x288	840x840x288
Packaging dimensions	WxDxH	mm	990x990x310	990x990x330	990x990x330	990x990x380	990x990x380
Net/gross weight		kg	27,0/32,0	31,0/36,0	31,0/36,0	32,0/38,0	32,0/38,0
Panel	Model		PB-950KB	PB-950KB	PB-950KB	PB-950KB	PB-950KB
Panel Net dimensions			950x950x50	950x950x50	950x950x50	950x950x50	950x950x50
Panel Packaging dimensions			1013x1025x123	1013x1025x123	1013x1025x123	1013x1025x123	1013x1025x123
Panel Net/gross weight			6,5/9,5	6,5/9,5	6,5/9,5	6,5/9,5	6,5/9,5
Outdoor Unit							
Power supply		Ph/V/Hz	1/220-240/50/60	1/220-240/50/60	3/380-415/50/60	1/220-240/50/60	3/380-415/50/60
Power cable		N x mm ²	3 x 4,0	3 x 4,0	5 x 4,0	3 x 6,0	5 x 4,0
Interconnection cable		N x mm ²	4 x 2,5	4 x 2,5	4 x 2,5	4 x 2,5	4 x 2,5
Sound power	H	dB	67	66	68	72	72
Sound pressure	H	dB(A)	54	53	54	58	58
Running current cooling/heating	Max	A	13,1	16,5	6,8	26,0	10,0
Starting current cooling/heating	Max	A	2,0	3,0	1,0	4,0	2,0
Net dimensions	WxDxH	mm	890x353x697	920*372*760	920*372*760	950x370x965	950x370x965
Packaging dimensions	WxDxH	mm	1046x460x780	1036*478*820	1085x485x830	1050x485x1130	1050x485x1130
Net/gross weight		kg	45,0/50,0	60,0/65,0	61,0/66,0	84,0/89,0	85,0/90,0
Compressor type			Twin rotary inverter	Twin rotary inverter	Twin rotary inverter	Twin rotary inverter	Twin rotary inverter
Installation data							
Refrigerant			R32	R32	R32	R32	R32
Liquid pipe	∅	mm (inch)	9,52 (3/8)	9,52 (3/8)	9,52 (3/8)	9,52 (3/8)	9,52 (3/8)
Gas pipe	∅	mm (inch)	15,88 (5/8)	15,88 (5/8)	15,88 (5/8)	15,88 (5/8)	15,88 (5/8)
Standard pipe length without refrigerant charge		m	10	30	30	30	30
Maximum pipe length		m	50	50	50	50	50
Maximum IU - OU elevation		m	30	30	30	30	30
Refrigerant charge in the factory		kg	1,30	1,70	1,70	2,30	2,30
Refrigerant charge in the factory		TCO _{2eq}	0,88	1,15	1,15	1,55	1,55
Additional ref. charge over std length		g/m	45	45	45	45	45
Outdoor operating limits - COOLING	min-max	°C			-10-46		
Outdoor operating limits - HEATING	min-max	°C			-15-24		

Commercial R32 ROUND FLOW CASSETTE



ABH140 - ABH160

1U140

1U140 - 1U160

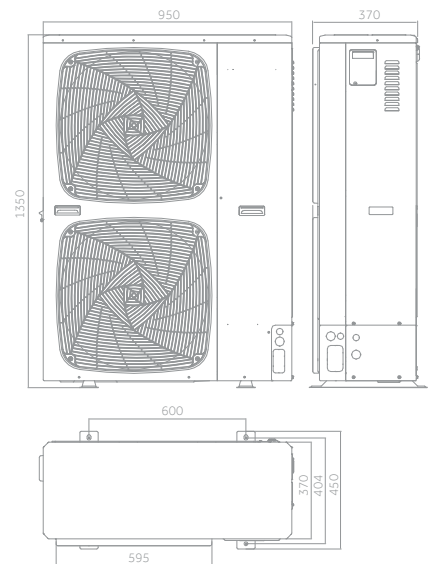
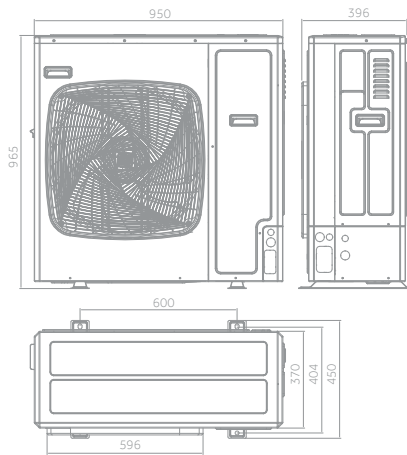
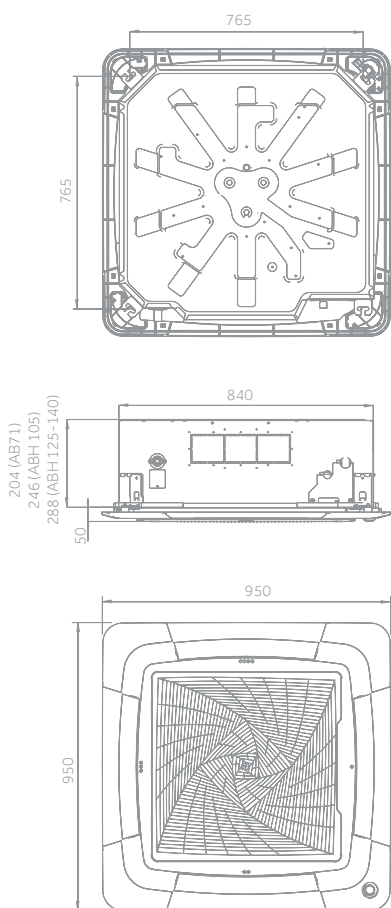

10,5 kW



14,0 kW



16,0 kW

Commercial R32 ROUND FLOW CASSETTE

Haier

14,0 kW

16,0 kW

OPTIONAL CONTROL



Silence



8way Independent



Wi-Fi Optional



Fresh Air



COMMERCIAL R32

- Low noise level
- Wi-Fi control (OPTIONAL)
- 'Fresh air' knockout is incorporated in the chassis to allow fresh air introduction of up to 20% of nominal unit air flow without compromising the cooling capacity. More than 20% of the air conditioner's thermal cooling capacity is penalise.
- Sensor (OPTIONAL) detects real-time air conditions and movement of people

Indoor Unit	Model		ABH140K1ERG	ABH140K1ERG	ABH140K1ERG	ABH140K1ERG	ABH160K1ERG
Outdoor Unit	Model		1U140S2SN1FA	1U140S2SN1FB	1U140S2SP2FA	1U140S2SP2FB	1U160S2SP1FB
Performance data							
Output power - COOLING	nom (min-max)	kW	13,40 (3,50-14,00)	13,40 (3,50-14,00)	13,60 (4,00-15,00)	13,60 (4,00-15,00)	15,00 (4,50-16,00)
Output power - HEATING	nom (min-max)	kW	15,00 (4,00-15,50)	15,00 (4,00-15,50)	15,00 (4,50-16,00)	15,00 (4,50-16,00)	16,00 (5,00-17,00)
Absorbed power - COOLING	nom (min-max)	kW	5,51 (1,00-6,50)	5,28 (1,00-6,50)	4,86 (1,00-6,00)	4,98 (1,00-6,00)	5,03 (1,00-6,50)
Absorbed power - HEATING	nom (min-max)	kW	5,77 (1,00-6,50)	5,70 (1,00-6,50)	4,75 (1,00-6,00)	4,67 (1,00-6,00)	5,26 (1,00-6,50)
Energy class	EER	W/W	2,43	2,54	2,80	2,73	2,98
	COP	W/W	2,60	2,63	3,10	3,06	3,04
COOLING Pdesign	35 °C	kW	13,40	13,40	13,60	13,60	15,00
HEATING Pdesign	(-10 °C)	kW	8,50	8,50	10	10	11,00
Energy class	SEER		5,60 (A+)	5,62 (A+)	5,70 (A+)	5,70 (A+)	5,96 (A+)
	SCOP		3,93 (A)	3,96 (A)	3,94 (A)	3,99 (A)	3,99 (A)
Annual Energy Consumption - COOLING		kWh/a	838	834	800	782	880
Annual Energy Consumption - HEATING		kWh/a	3032	3003	3768	3748	3859
Indoor Unit							
Power supply		Ph/V/Hz	1/220-240/50/60	1/220-240/50/60	1/220-240/50/60	1/220-240/50/60	1/220-240/50/60
Treated air volume	(H/M/L/Q)	m ³ /h	1950/1600/1440/1200	1950/1600/1440/1200	1950/1600/1440/1200	1950/1600/1440/1200	2050/1600/1440/1220
High sound power		dB	64	64	64	64	65
Sound pressure		dB(A)	47/44/38/34	47/44/38/34	47/44/38/34	47/44/38/34	48/44/38/34
Net dimensions	WxDxH	mm	840x840x288	840x840x288	840x840x288	840x840x288	840x840x288
Packaging dimensions	WxDxH	mm	990x990x380	990x990x380	990x990x380	990x990x380	990x990x380
Net/gross weight		kg	32,0/38,0	32,0/38,0	32,0/38,0	32,0/38,0	32,0/38,0
Panel	Model		PB-950KB	PB-950KB	PB-950KB	PB-950KB	PB-950KB
Panel Net dimensions			950x950x50	950x950x50	950x950x50	950x950x50	950x950x50
Panel Packaging dimensions			1013x1025x123	1013x1025x123	1013x1025x123	1013x1025x123	1013x1025x123
Panel Net/gross weight			6,5/9,5	6,5/9,5	6,5/9,5	6,5/9,5	6,5/9,5
Outdoor Unit							
Power supply		Ph/V/Hz	1/220-240/50/60	3/380-415/50/60	1/220-240/50/60	3/380-415/50/60	3/380-415/50/60
Power cable		N x mm ²	3 x 6,0	5 x 4,0	3 x 6,0	5 x 4,0	5 x 4,0
Interconnection cable		N x mm ²	4 x 2,5	4 x 2,5	4 x 2,5	4 x 2,5	4 x 2,5
Sound power	H	dB	72	72	70	70	72
Sound pressure	H	dB(A)	58	58	53	53	58
Running current cooling/heating	Max	A	30,0	10,0	32,0	10,0	10,0
Starting current cooling/heating	Max	A	5,0	2,0	6,0	2,0	2,0
Net dimensions	WxDxH	mm	950x370x965	950x370x965	950x370x1350	950x370x1350	950x370x1350
Packaging dimensions	WxDxH	mm	1050x485x1130	1050x485x1130	1050x485x1500	1050x485x1500	1050x485x1500
Net/gross weight		kg	84,0/89,0	85,0/90,0	105,0/118,0	101,0/116,0	101,0/116,0
Compressor type			Twin rotary inverter	Twin rotary inverter	Twin rotary inverter	Twin rotary inverter	Twin rotary inverter
Installation data							
Refrigerant			R32	R32	R32	R32	R32
Liquid pipe	∅	mm (inch)	9,52 (3/8)	9,52 (3/8)	9,52 (3/8)	9,52 (3/8)	9,52 (3/8)
Gas pipe	∅	mm (inch)	15,88 (5/8)	15,88 (5/8)	15,88 (5/8)	15,88 (5/8)	19,05 (3/4)
Standard pipe length without refrigerant charge		m	30	30	30	30	30
Maximum pipe length		m	70	70	70	70	70
Maximum IU - OU elevation		m	30	30	30	30	30
Refrigerant charge in the factory		kg	2,30	2,30	2,90	3,50	3,50
Refrigerant charge in the factory		TCO _{2eq}	1,55	1,55	1,96	2,36	2,36
Additional ref. charge over std length		g/m	45	45	45	45	45
Outdoor operating limits - COOLING	min-max	°C			-10-46		
Outdoor operating limits - HEATING	min-max	°C			-15-24		

Commercial R32 CEILING FLOOR



Commercial R32 CEILING FLOOR

INTELLIGENT SENSOR optional

The sensor detects the number, position and movement of people to provide optimal temperature control with direct and indirect flows.

This technology reduces energy consumption by about 27%, without sacrificing comfort.

FLOW +

The air is distributed equally in every corner of the room to ensure maximum comfort.

The unit can be installed on the ceiling at a height of 4,2 m.

EASY PCB MAINTENANCE

Easy to wire and maintain PCB: simply open the grille.

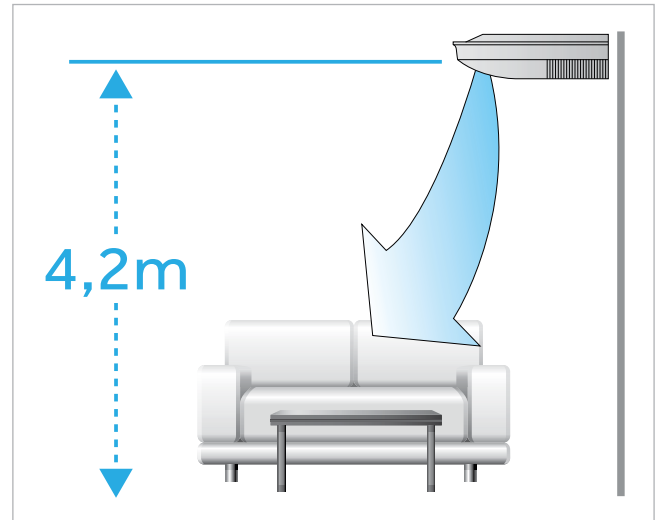

SILENCE

The use of DC Inverter fans and optimised design reduces the noise level of the indoor units.

Minimum level of sound pressure of only 33dB(A).

The upper of volute extends direction and reduced the noise.



5 SPEED FAN

The fan speed can be set to 5 different programs: Turbo - High - Medium - Low - Super Low.

(Only with YR-HB or wired controllers)

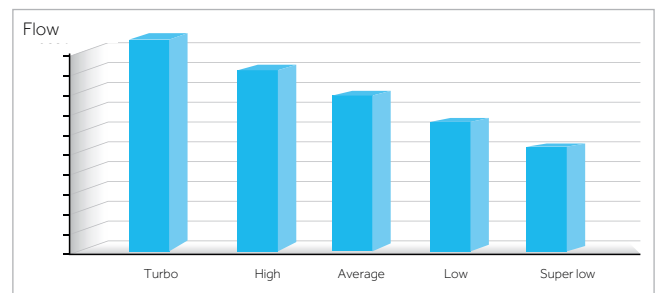

FRESH AIR

Air exchange allows introduction of clean air into the room.

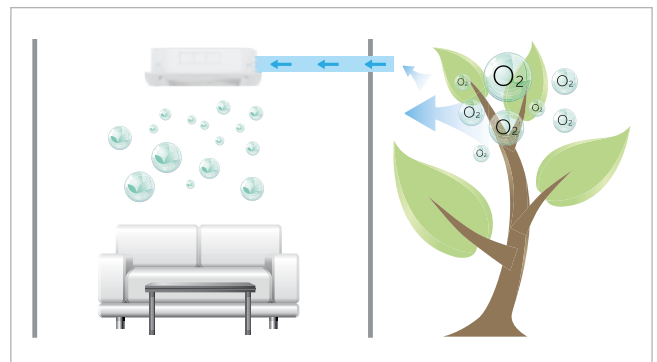

Commercial R32 CEILING FLOOR



AC35 - AC50 - AC71

1U35

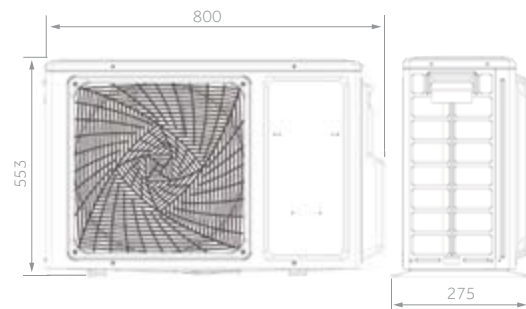
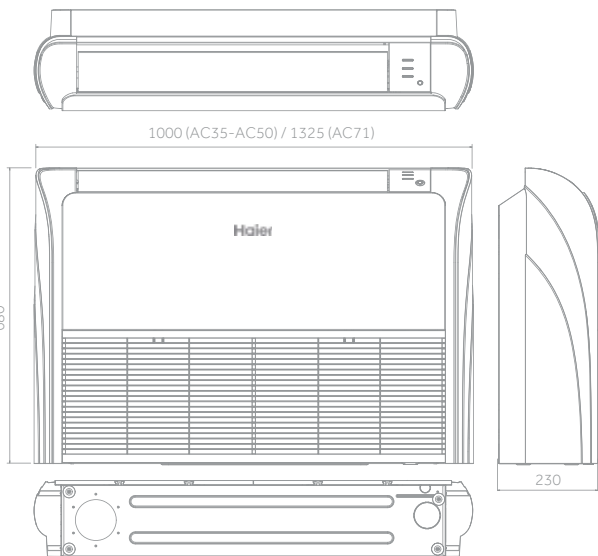

1U50

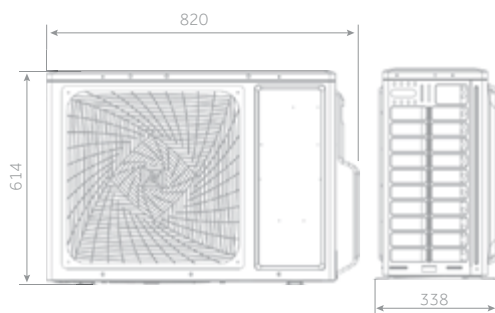

1U71

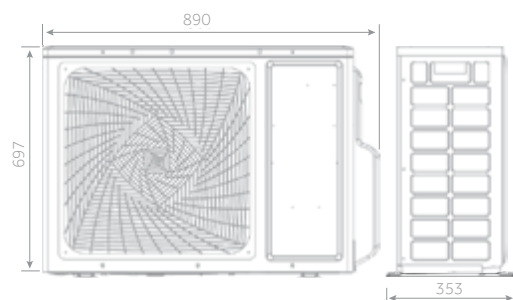

3,5 kW

5,0 kW

7,1 kW

Commercial R32 CEILING FLOOR

Haier

3,5 kW

5,0 kW

7,1 kW

COMMERCIAL R32



(AC71S2SG1FA only)

OPTIONAL CONTROL



Silence



Flow +



5 Speed Fan



Fresh Air

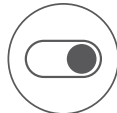

On-Off Card

≥AC71) CEILING		≥AC71) FLOOR	
m (kg)	Sup. (m²)	m (kg)	Sup. (m²)
1,23	0,95	1,23	12,90
1,40	1,25	1,40	16,80
1,60	1,63	1,60	22,00
1,80	2,07	1,80	27,80
2,00	2,55	2,00	34,30
2,20	3,09	2,20	41,50
2,40	3,68	2,40	49,40
2,60	4,31	2,60	58,00
2,80	5,00	2,80	67,30
3,00	5,74	3,00	77,20

- Low noise level
- Flow +: Internal deflectors are divided into two groups with independent motors (independent right-left airflow)
- 5 fan speed: turbo, high, medium, low, super low (only with YR-HQS01 or wired controller)
- 'Fresh air' knockout is incorporated in the chassis to allow fresh air introduction of up to 20% of nominal unit air flow without compromising the cooling capacity. More than 20% of the air conditioner's thermal cooling capacity is penalise.

Indoor Unit	Model	AC35S2SG1FA	AC50S2SG1FA	AC71S2SG1FA
Outdoor Unit	Model	1U35S2SM1FA-2	1U50S2S2FA	1U71S2SR2FA
Performance data				
Output power - COOLING	nom (min-max) kW	3,50 (1,00-4,30)	5,00 (1,40-5,70)	7,10 (2,00-7,30)
Output power - HEATING	nom (min-max) kW	4,00 (1,00-5,30)	5,80 (1,40-6,00)	7,50 (2,50-8,00)
Absorbed power - COOLING	nom (min-max) kW	0,91 (0,30-1,50)	1,45 (0,50-2,00)	2,20 (0,50-3,00)
Absorbed power - HEATING	nom (min-max) kW	1,07 (0,50-1,60)	1,56 (0,52-2,35)	2,02 (0,50-3,00)
Energy class	EER	W/W	3,81	3,23
	COP	W/W	3,73	3,71
COOLING Pdesign	35 °C	kW	3,50	7,10
HEATING Pdesign	(-10 °C)	kW	3,00	5,00
Energy class	SEER		8,50 (A+++)	6,10 (A++)
	SCOP		4,47 (A+)	3,80 (A)
Annual Energy Consumption - COOLING	kWh/a	146	240	407
Annual Energy Consumption - HEATING	kWh/a	945	1491	1832
Indoor Unit				
Power supply	Ph/V/Hz	1/220-240/50/60	1/220-240/50/60	1/220-240/50/60
Treated air volume	(H/M/L/Q)	m³/h	750/620/500/400	880/750/650/500
High sound power		dB	53	57
Sound pressure		dB(A)	39/36/33/30	44/41/38/35
Net dimensions	WxDxH	mm	1000x230x680	1000x230x680
Packaging dimensions	WxDxH	mm	1100x305x779	1100x305x779
Net/gross weight		kg	26,0/32,0	26,0/32,0
Outdoor Unit				
Power supply	Ph/V/Hz	1/220-240/50	1/220-240/50	1/220-240/50/60
Power cable	N x mm²	3 x 1,5	3 x 1,5	3 x 4,0
Interconnection cable	N x mm²	4 x 1,0	4 x 1,0	4 x 2,5
Sound power	H	dB	61	63
Sound pressure	H	dB(A)	48	51
Running current cooling/heating	Max	A	8,0	9,5
Starting current cooling/heating	Max	A	2,0	2,0
Net dimensions	WxDxH	mm	800x275x553	820x338x614
Packaging dimensions	WxDxH	mm	908x405x625	993x413x685
Net/gross weight		kg	30,0/32,9	37,8/41,5
Compressor type			Rotary inverter	Twin rotary inverter
Installation data				
Refrigerant			R32	R32
Liquid pipe	∅	mm (inch)	6,35 (1/4)	6,35 (1/4)
Gas pipe	∅	mm (inch)	9,52 (3/8)	12,70 (1/2)
Standard pipe length without refrigerant charge		m	7	7
Maximum pipe length		m	15	25
Maximum IU - OU elevation		m	10	15
Refrigerant charge in the factory		kg	0,78	0,95
Refrigerant charge in the factory		TCO2eq	0,53	0,64
Additional ref. charge over std length		g/m	20	20
Outdoor operating limits - COOLING	min-max	°C		-10-46
Outdoor operating limits - HEATING	min-max	°C		-15-24

Commercial R32 CEILING FLOOR



AC105 - AC125

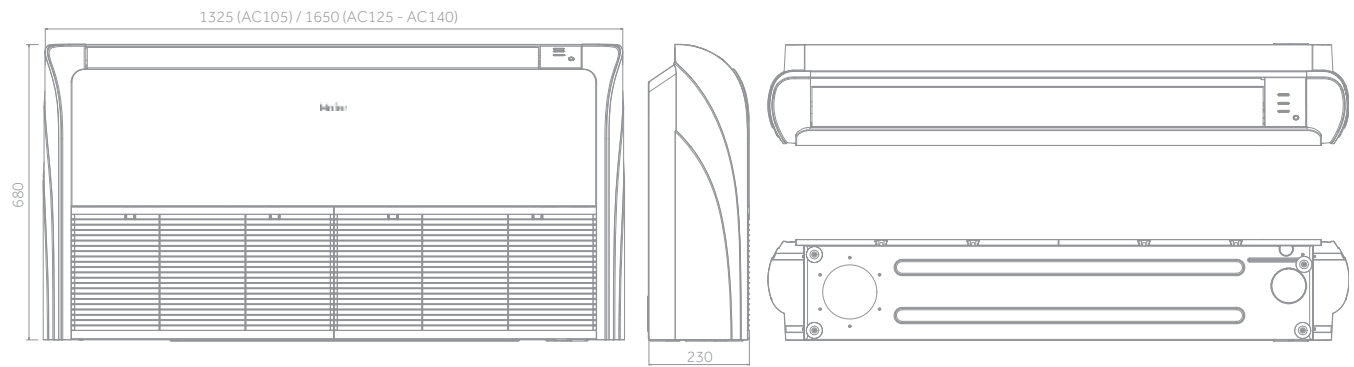

1U105

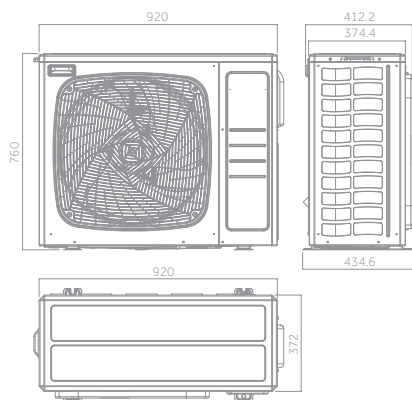

1U125

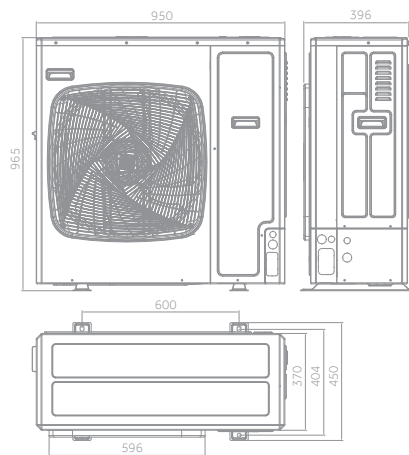

10,5 kW



12,5 kW

Commercial R32 CEILING FLOOR

Haier

10,5 kW

12,5 kW

OPTIONAL CONTROL

COMMERCIAL R32



Silence



Flow +



5 Speed Fan



Fresh Air

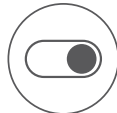

On-Off Card

≥AC71) CEILING		≥AC71) FLOOR	
m (kg)	Sup. (m ²)	m (kg)	Sup. (m ²)
1,23	0,95	1,23	12,90
1,40	1,25	1,40	16,80
1,60	1,63	1,60	22,00
1,80	2,07	1,80	27,80
2,00	2,55	2,00	34,30
2,20	3,09	2,20	41,50
2,40	3,68	2,40	49,40
2,60	4,31	2,60	58,00
2,80	5,00	2,80	67,30
3,00	5,74	3,00	77,20

- Low noise level
- Flow +: Internal deflectors are divided into two groups with independent motors (independent right-left airflow)
- 5 fan speed: turbo, high, medium, low, super low (only with YR-HQS01 or wired controller)
- 'Fresh air' knockout is incorporated in the chassis to allow fresh air introduction of up to 20% of nominal unit air flow without compromising the cooling capacity. More than 20% of the air conditioner's thermal cooling capacity is penalise.

Indoor Unit	Model	AC105S2SH1FA	AC105S2SH1FA	AC125S2SK1FA	AC125S2SK1FA
Outdoor Unit	Model	1U105S2SS2FA	1U105S2SS1FB	1U125S2SN2FA	1U125S2SN2FB
Performance data					
Output power - COOLING	nom (min-max) kW	9,50 (2,50-10,00)	9,50 (2,50-10,00)	12,30 (3,00-13,00)	12,40 (3,00-13,00)
Output power - HEATING	nom (min-max) kW	10,20 (3,00-10,50)	10,50 (3,00-11,00)	12,70 (3,50-13,50)	12,80 (3,50-13,50)
Absorbed power - COOLING	nom (min-max) kW	3,13 (0,50-4,00)	3,25 (0,50-4,00)	4,54 (1,00-6,00)	4,53 (1,00-6,00)
Absorbed power - HEATING	nom (min-max) kW	3,07 (0,50-4,00)	3,10 (0,50-4,00)	3,96 (1,00-6,00)	3,93 (1,00-6,00)
Energy class	EER	W/W	3,04	2,90	2,74
	COP	W/W	3,32	3,50	3,26
COOLING Pdesign	35 °C	kW	9,50	9,50	12,30
HEATING Pdesign	(-10 °C)	kW	7,00	6,00	8
Energy class	SEER		6,11 (A++)	6,11 (A++)	5,86 (A+)
	SCOP		3,80 (A)	3,91 (A)	3,97 (A)
Annual Energy Consumption - COOLING	kWh/a	549	557	738	742
Annual Energy Consumption - HEATING	kWh/a	2750	2228	2995	2976
Indoor Unit					
Power supply		Ph/V/Hz	1/220-240/50/60	1/220-240/50/60	1/220-240/50/60
Treated air volume	(H/M/L/Q)	m ³ /h	1600/1400/1280/1160	1600/1400/1280/1160	2050/1900/1600/1400
High sound power		dB	61	63	64
Sound pressure		dB(A)	47/43/41/37	47/43/41/37	46/43/41/38
Net dimensions	WxDxH	mm	1325x230x680	1325x230x680	1650x230x680
Packaging dimensions	WxDxH	mm	1425x305x779	1425x305x779	1750x305x779
Net/gross weight		kg	33,5/41,9	33,5/41,9	43,0/51,0
Outdoor Unit					
Power supply		Ph/V/Hz	1/220-240/50/60	3/380-415/50/60	1/220-240/50/60
Power cable		N x mm ²	3 x 4,0	5 x 4,0	3 x 6,0
Interconnection cable		N x mm ²	4 x 2,5	4 x 2,5	4 x 2,5
Sound power	H	dB	66	68	72
Sound pressure	H	dB(A)	53	54	58
Running current cooling/heating	Max	A	16,5	6,8	26,0
Starting current cooling/heating	Max	A	3,0	1,0	4,0
Net dimensions	WxDxH	mm	920*372*760	920*372*760	950x370x965
Packaging dimensions	WxDxH	mm	1036*478*820	1085x485x830	1050x485x1130
Net/gross weight		kg	60,0/65,0	61,0/66,0	84,0/89,0
Compressor type			Twin rotary inverter	Twin rotary inverter	Twin rotary inverter
Installation data					
Refrigerant			R32	R32	R32
Liquid pipe	Ø	mm (inch)	9,52 (3/8)	9,52 (3/8)	9,52 (3/8)
Gas pipe	Ø	mm (inch)	15,88 (5/8)	15,88 (5/8)	15,88 (5/8)
Standard pipe length without refrigerant charge		m	30	30	30
Maximum pipe length		m	50	50	50
Maximum IU - OU elevation		m	30	30	30
Refrigerant charge in the factory		kg	1,70	1,70	2,30
Refrigerant charge in the factory		TCO ₂ eq	1,15	1,15	1,55
Additional ref. charge over std length		g/m	45	45	45
Outdoor operating limits - COOLING	min-max	°C			-10-46
Outdoor operating limits - HEATING	min-max	°C			-15-24

Commercial R32 CEILING FLOOR



AC140 - AC160

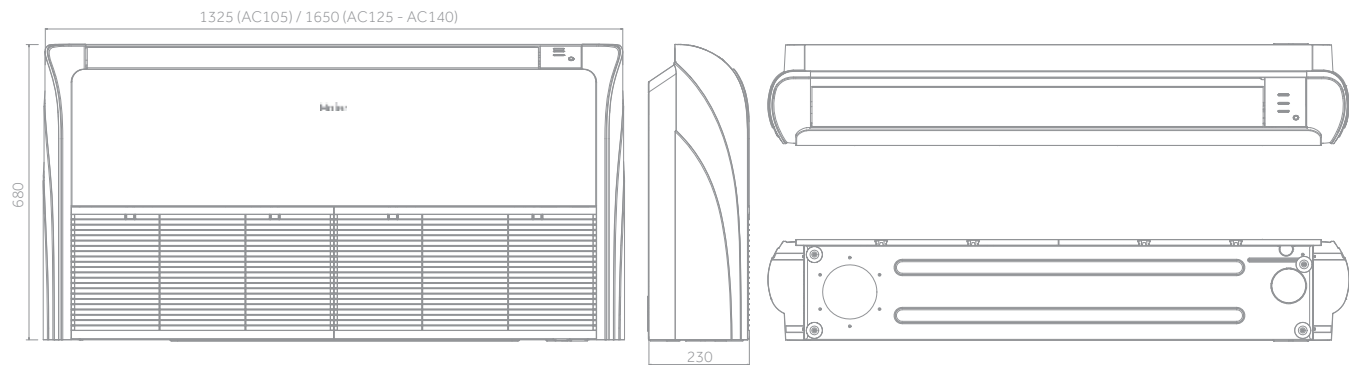

1U140

1U140 - 1U160

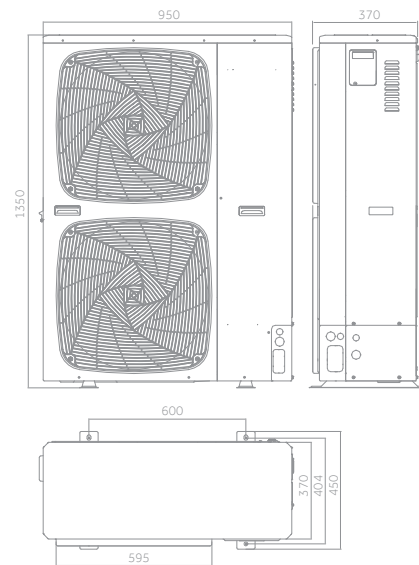
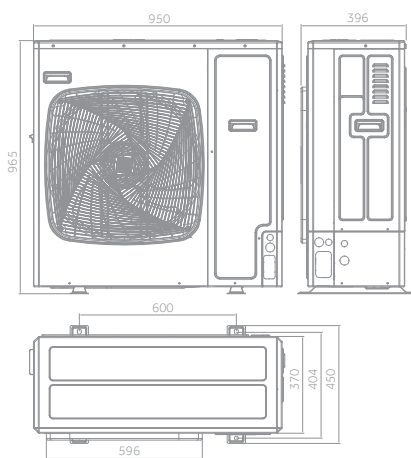

14,0 kW



14,0 kW



16,0 kW

Commercial R32 CEILING FLOOR

Haier

14,0 kW

16,0 kW

OPTIONAL CONTROL

COMMERCIAL R32



Silence



Flow +



5 Speed Fan



Fresh Air



On-Off Card

- Low noise level
- Flow +: Internal deflectors are divided into two groups with independent motors (independent right-left airflow)
- 5 fan speed: turbo, high, medium, low, super low (only with YR-HQS01 or wired controller)
- 'Fresh air' knockout is incorporated in the chassis to allow fresh air introduction of up to 20% of nominal unit air flow without compromising the cooling capacity. More than 20% of the air conditioner's thermal cooling capacity is penalise.

≥AC71) CEILING		≥AC71) FLOOR	
m (kg)	Sup. (m²)	m (kg)	Sup. (m²)
1,23	0,95	1,23	12,90
1,40	1,25	1,40	16,80
1,60	1,63	1,60	22,00
1,80	2,07	1,80	27,80
2,00	2,55	2,00	34,30
2,20	3,09	2,20	41,50
2,40	3,68	2,40	49,40
2,60	4,31	2,60	58,00
2,80	5,00	2,80	67,30
3,00	5,74	3,00	77,20

Indoor Unit	Model	AC140S2SK1FA	AC140S2SK1FA	AC140S2SK1FA	AC140S2SK1FA	AC160S2SK1FA	
Outdoor Unit	Model	1U140S2SN1FA	1U140S2SN1FB	1U140S2SP2FA	1U140S2SP2FB	1U160S2SP1FB	
Performance data							
Output power - COOLING	nom (min-max) kW	13,40 (3,50-14,00)	13,40 (3,50-14,00)	13,60 (4,00-15,00)	13,60 (4,00-15,00)	16,00 (4,50-16,50)	
Output power - HEATING	nom (min-max) kW	15,00 (4,00-15,50)	15,00 (4,00-15,50)	15,00 (4,50-16,00)	15,00 (4,50-16,00)	17,00 (5,00-18,00)	
Absorbed power - COOLING	nom (min-max) kW	5,23 (1,00-6,50)	5,13 (1,00-6,50)	4,53 (1,00-6,00)	4,53 (1,00-6,00)	5,39 (1,00-6,50)	
Absorbed power - HEATING	nom (min-max) kW	5,08 (1,00-6,50)	4,97 (1,00-6,50)	4,17 (1,00-6,00)	4,29 (1,00-6,00)	4,97 (1,00-6,50)	
Energy class	EER	W/W	2,56	2,61	3,00	3,00	2,97
	COP	W/W	2,95	3,02	3,60	3,50	3,42
COOLING Pdesign	35 °C	kW	13,40	13,40	13,60	13,60	16,00
HEATING Pdesign	(-10 °C)	kW	8,50	8,50	10	10	11,00
Energy class	SEER		5,92 (A+)	5,97 (A+)	6,16 (A++)	6,18 (A++)	6,06 (A+)
	SCOP		3,97 (A)	4,00 (A+)	4,06 (A+)	4,06 (A+)	4,06 (A+)
Annual Energy Consumption - COOLING	kWh/a	792	786	761	759	924	
Annual Energy Consumption - HEATING	kWh/a	2995	2976	3791	3791	3791	
Indoor Unit							
Power supply	Ph/V/Hz	1/220-240/50/60	1/220-240/50/60	1/220-240/50/60	1/220-240/50/60	1/220-240/50/60	
Treated air volume	(H/M/L/Q)	m3/h	2150/1980/1800/1600	2150/1980/1800/1600	2150/1980/1800/1600	2250/2000/1850/1650	
High sound power		dB	66	66	66	66	67
Sound pressure		dB(A)	48/46/43/40	48/46/43/40	48/46/43/40	48/46/43/40	48/46/43/40
Net dimensions	WxDxH	mm	1650x230x680	1650x230x680	1650x230x680	1650x230x680	
Packaging dimensions	WxDxH	mm	1750x305x779	1750x305x779	1750x305x779	1750x305x779	
Net/gross weight		kg	43,0/51,0	43,0/51,0	43,0/51,0	43,0/51,0	
Outdoor Unit							
Power supply	Ph/V/Hz	1/220-240/50/60	3/380-415/50/60	1/220-240/50/60	3/380-415/50/60	3/380-415/50/60	
Power cable	N x mm2	3 x 6,0	5 x 4,0	3 x 6,0	5 x 4,0	5 x 4,0	
Interconnection cable	N x mm2	4 x 2,5	4 x 2,5	4 x 2,5	4 x 2,5	4 x 2,5	
Sound power	H	dB	72	72	70	70	72
Sound pressure	H	dB(A)	58	58	53	53	58
Running current cooling/heating	Max	A	30,0	10,0	32,0	10,0	10,0
Starting current cooling/heating	Max	A	5,0	2,0	6,0	2,0	2,0
Net dimensions	WxDxH	mm	950x370x965	950x370x965	950x370x1350	950x370x1350	950x370x1350
Packaging dimensions	WxDxH	mm	1050x485x1130	1050x485x1130	1050x485x1500	1050x485x1500	1050x485x1500
Net/gross weight		kg	84,0/89,0	85,0/90,0	105,0/118,0	101,0/116,0	101,0/116,0
Compressor type			Twin rotary inverter	Twin rotary inverter	Twin rotary inverter	Twin rotary inverter	Twin rotary inverter
Installation data							
Refrigerant			R32	R32	R32	R32	R32
Liquid pipe	∅	mm (inch)	9,52 (3/8)	9,52 (3/8)	9,52 (3/8)	9,52 (3/8)	9,52 (3/8)
Gas pipe	∅	mm (inch)	15,88 (5/8)	15,88 (5/8)	15,88 (5/8)	15,88 (5/8)	19,05 (3/4)
Standard pipe length without refrigerant charge		m	30	30	30	30	30
Maximum pipe length		m	70	70	70	70	70
Maximum IU - OU elevation		m	30	30	30	30	30
Refrigerant charge in the factory		kg	2,30	2,30	2,90	3,50	3,50
Refrigerant charge in the factory		TCO2eq	1,55	1,55	1,96	2,36	2,36
Additional ref. charge over std length		g/m	45	45	45	45	45
Outdoor operating limits - COOLING	min-max	°C			-10-46		
Outdoor operating limits - HEATING	min-max	°C			-15-24		

The data in this catalogue is purely indicative as the data may vary. Please be advised to check the accuracy of the data with the supplier before purchasing products.

Commercial R32 SLIM DUCT LOW PRESSURE



THE PANEL KIT (OPTIONAL) INCLUDES:

Air supply grill equipped with vertical and horizontal fins motorised 3D effect - receiver - display

Air intake grill equipped with filter



AD35 - AD50 - AD71

1U35

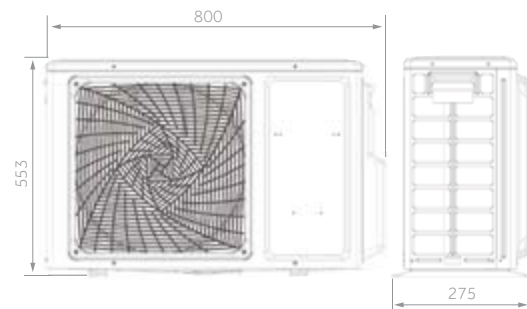
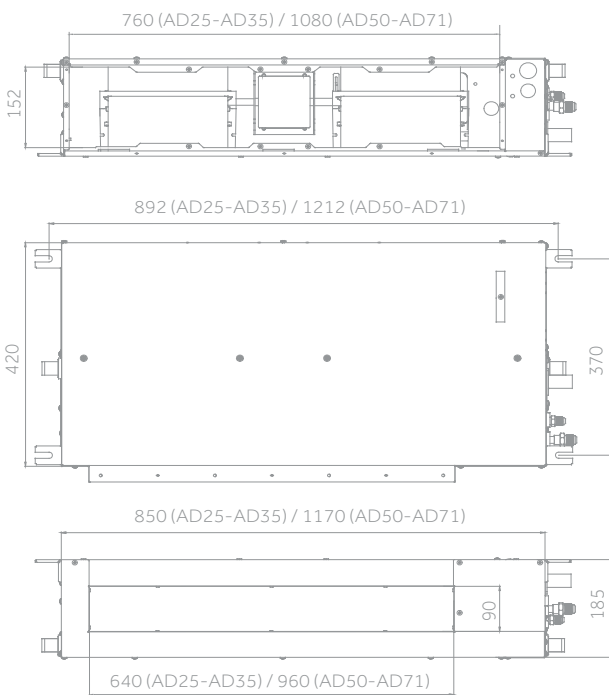

1U50

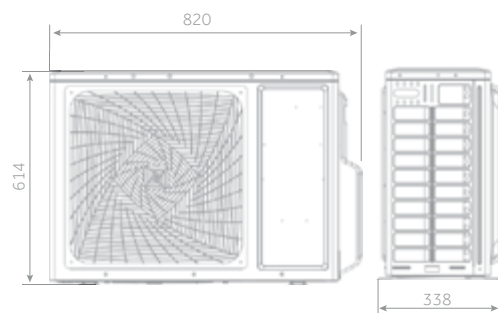

1U71

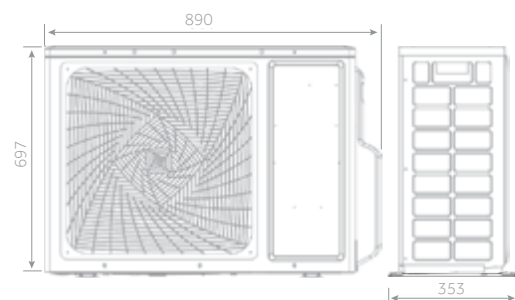

3,5 kW

5,0 kW

7,1 kW

Commercial R32 SLIM DUCT LOW PRESSURE

Haier

3,5 kW

5,0 kW

7,1 kW

OPTIONAL CONTROL



Silence

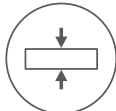

Compact Design



3D



Condensate
Drain Pump



Flexible
Installation



AD71S2SS1FA

- Low noise level
- Compact design
- Panel kit (OPTIONAL): air supply and intake grill
- Condensate drain pump
- Flexible installation

Indoor Unit	Model		AD35S2SS1FA	AD50S2SS1FA	AD71S2SS1FA
Outdoor Unit	Model		1U35S2SM1FA	1U50S2S2FA	1U71S2SR2FA
Performance data					
Output power - COOLING	nom (min-max)	kW	3,50 (0,90-4,50)	5,00 (1,80-6,00)	7,10 (2,00-7,60)
Output power - HEATING	nom (min-max)	kW	4,00 (1,00-4,80)	5,50 (2,00-6,20)	7,50 (3,00-8,30)
Absorbed power - COOLING	nom (min-max)	kW	1,06 (0,28-1,80)	1,53 (0,55-2,10)	2,20 (0,50-3,00)
Absorbed power - HEATING	nom (min-max)	kW	1,07 (0,28-1,80)	1,47 (0,60-2,10)	2,01 (0,60-2,90)
Energy class	EER	W/W	3,30	3,26	3,24
	COP	W/W	3,73	3,73	3,73
COOLING Pdesign	35 °C	kW	3,50	5,00	7,10
HEATING Pdesign	(-10 °C)	kW	3,00	4,30	5,00
Energy class	SEER		6,10 (A++)	6,10 (A++)	6,10 (A++)
	SCOP		3,80 (A)	3,80 (A)	3,80 (A)
Annual Energy Consumption - COOLING		kWh/a	241	315	406
Annual Energy Consumption - HEATING		kWh/a	1427	1961	1836
Indoor Unit					
Power supply		Ph/V/Hz	1/220-240/50/60	1/220-240/50/60	1/220-240/50/60
Treated air volume	(H/M/L/Q)	m3/h	600/480/420/350	900/750/600	1000/850/750
External static pressure		Pa	0/10/20/40		
High sound power		dB	53	54	57
Sound pressure		dB(A)	33/28/25	36/34/32	49/46/44/42
Net dimensions	WxDxH	mm	850x420x185	1170x420x185	1170x420x185
Packaging dimensions	WxDxH	mm	1045x530x260	1365x530x260	1365x530x260
Net/gross weight		kg	16,0/21,0	22,0/28,0	25,2/28,4
Panel (optional)	Model		P1B-890IA/D	P1B-1210IA/D	P1B-1210IA/D
Panel Net dimensions			890x190x100(outlet panel) 890x290,5x32,4(inlet panel)	1210x190x100(outlet panel) 1210x290,5x32,4(inlet panel)	
Panel Packaging dimensions			938x335x220	1258x335x220	1258x335x220
Panel Net/gross weight			4,0/5,0	5,0/6,0	5,0/6,0
Outdoor Unit					
Power supply		Ph/V/Hz	1/220-240/50	1/220-240/50	1/220-240/50/60
Power cable		N x mm2	3 x 1,5	3 x 1,5	3 x 4,0
Interconnection cable		N x mm2	4 x 1,0	4 x 1,0	4 x 2,5
Sound power	H	dB	61	63	67
Sound pressure	H	dB(A)	48	51	54
Running current cooling/heating	Max	A	8,0	9,5	13,1
Starting current cooling/heating	Max	A	2,0	2,0	2,0
Net dimensions	WxDxH	mm	800x275x553	820x338x614	890x353x697
Packaging dimensions	WxDxH	mm	908x405x625	993x413x685	1046x460x780
Net/gross weight		kg	30,0/32,9	37,8/41,5	45,0/50,0
Compressor type			Rotary inverter	Twin rotary inverter	Twin rotary inverter
Installation data					
Refrigerant			R32	R32	R32
Liquid pipe	Ø	mm (inch)	6,35 (1/4)	6,35 (1/4)	9,52 (3/8)
Gas pipe	Ø	mm (inch)	9,52 (3/8)	12,70 (1/2)	15,88 (5/8)
Standard pipe length without refrigerant charge		m	7	7	10
Maximum pipe length		m	15	25	50
Maximum IU - OU elevation		m	10	15	30
Refrigerant charge in the factory		kg	0,78	0,95	1,30
Refrigerant charge in the factory		TCO2eq	0,53	0,64	0,88
Additional ref. charge over std length		g/m	20	20	45
Outdoor operating limits - COOLING	min-max	°C		-10-46	
Outdoor operating limits - HEATING	min-max	°C		-15-24	

Commercial R32 SLIM DUCT LOW PRESSURE



THE PANEL KIT (OPTIONAL) INCLUDES:

Air supply grill equipped with vertical and horizontal fins motorised 3D effect - receiver - display

Air intake grill equipped with filter



AD35 - AD50 - AD71

1U35

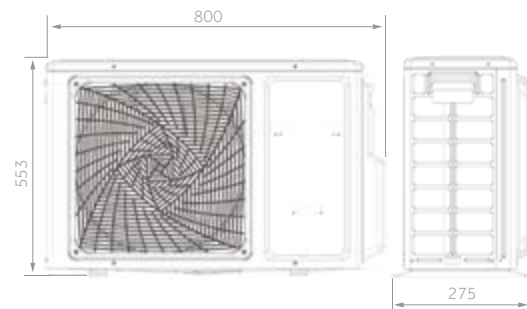
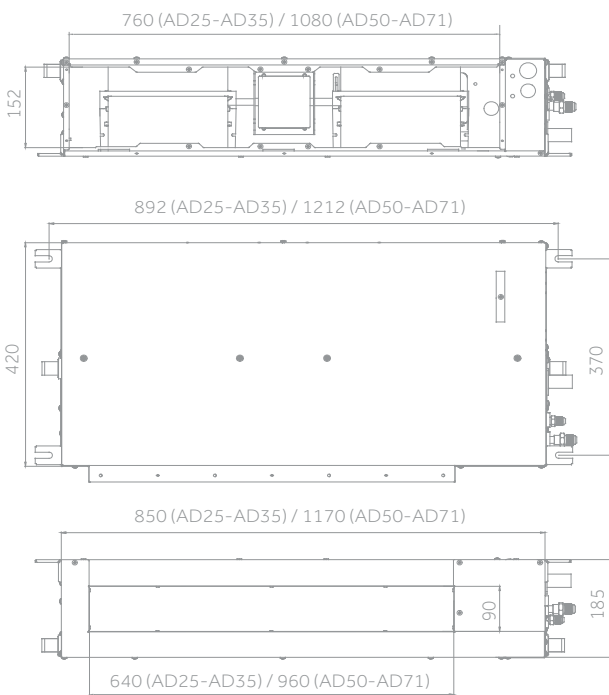

1U50

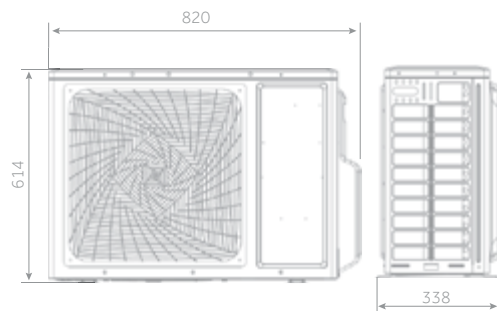

1U71

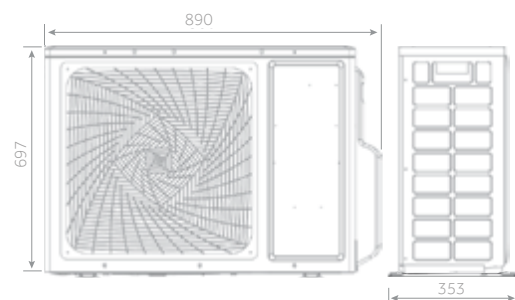

3,5 kW

5,0 kW

7,1 kW

Commercial R32 SLIM DUCT LOW PRESSURE

NEW

Haier

3,5 kW

5,0 kW

7,1 kW

OPTIONAL CONTROL



Silence

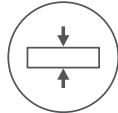

Compact Design



3D



Condensate
Drain Pump



Flexible
Installation

NEW



UVC Sterilisation

NEW



Wi-Fi control
integrated



AD71S2SS1FA/
AD71S2SS1FA(H)

- Low noise level
- Compact design
- Panel kit (OPTIONAL): air supply and intake grill
- Condensate drain pump
- Flexible installation
- UVC Sterilisation
- Wi-Fi control integrated

Indoor Unit	Model		AD35S2SS1FA(H)	AD50S2SS1FA(H)	AD71S2SS1FA(H)
Outdoor Unit	Model		1U35S2SM1FA-2	1U50S2S2FA	1U71S2SR2FA
Performance data					
Output power - COOLING	nom (min-max)	kW	3,50 (0,90-4,50)	5,00 (1,80-6,00)	7,10 (2,00-7,60)
Output power - HEATING	nom (min-max)	kW	4,00 (1,00-4,80)	5,50 (2,00-6,20)	7,50 (3,00-8,30)
Absorbed power - COOLING	nom (min-max)	kW	1,06 (0,28-1,80)	1,53 (0,55-2,10)	2,20 (0,50-3,00)
Absorbed power - HEATING	nom (min-max)	kW	1,07 (0,28-1,80)	1,47 (0,60-2,10)	2,01 (0,60-2,90)
Energy class	EER	W/W	3,30	3,26	3,24
	COP	W/W	3,73	3,73	3,73
COOLING Pdesign	35 °C	kW	3,50	5,00	7,10
HEATING Pdesign	(-10 °C)	kW	3,00	4,30	5,00
Energy class	SEER		6,10 (A++)	6,10 (A++)	6,10 (A++)
	SCOP		3,80 (A)	3,80 (A)	3,80 (A)
Annual Energy Consumption - COOLING		kWh/a	241	315	406
Annual Energy Consumption - HEATING		kWh/a	1427	1961	1836
Indoor Unit					
Power supply		Ph/V/Hz	1/220-240/50/60	1/220-240/50/60	1/220-240/50/60
Treated air volume	(H/M/L/Q)	m ³ /h	600/480/420/350	900/750/600	1000/850/750
External static pressure		Pa	0/10/20/40		
High sound power		dB	53	54	57
Sound pressure		dB(A)	33/28/25	36/34/32	49/46/44/42
Net dimensions	WxDxH	mm	850x420x185	1170x420x185	1170x420x185
Packaging dimensions	WxDxH	mm	1045x530x260	1365x530x260	1365x530x260
Net/gross weight		kg	16,0/21,0	22,0/28,0	25,2/28,4
Panel (optional)	Model		P1B-890IA/D	P1B-1210IA/D	P1B-1210IA/D
Panel Net dimensions			890x190x100 (outlet panel) x 890x290,5x32,4 (inlet panel)	1210x190x100 (outlet panel) x 1210x290,5x32,4 (inlet panel)	
Panel Packaging dimensions			938x335x220	1258x335x220	1258x335x220
Panel Net/gross weight			4,0/5,0	5,0/6,0	5,0/6,0
Outdoor Unit					
Power supply		Ph/V/Hz	1/220-240/50	1/220-240/50	1/220-240/50/60
Power cable		N x mm ²	3 x 1,5	3 x 1,5	3 x 4,0
Interconnection cable		N x mm ²	4 x 1,0	4 x 1,0	4 x 2,5
Sound power	H	dB	61	63	67
Sound pressure	H	dB(A)	48	51	54
Running current cooling/heating	Max	A	8,0	9,5	13,1
Starting current cooling/heating	Max	A	2,0	2,0	2,0
Net dimensions	WxDxH	mm	800x275x553	820x338x614	890x353x697
Packaging dimensions	WxDxH	mm	908x405x625	993x413x685	1046x460x780
Net/gross weight		kg	30,0/32,9	37,8/41,5	45,0/50,0
Compressor type			Rotary inverter	Twin rotary inverter	Twin rotary inverter
Installation data					
Refrigerant			R32	R32	R32
Liquid pipe	∅	mm (inch)	6,35 (1/4)	6,35 (1/4)	9,52 (3/8)
Gas pipe	∅	mm (inch)	9,52 (3/8)	12,70 (1/2)	15,88 (5/8)
Standard pipe length without refrigerant charge		m	7	7	10
Maximum pipe length		m	15	25	50
Maximum IU - OU elevation		m	10	15	30
Refrigerant charge in the factory		kg	0,78	0,95	1,30
Refrigerant charge in the factory		TCO ₂ eq	0,53	0,64	0,88
Additional ref. charge over std length		g/m	20	20	45
Outdoor operating limits - COOLING	min-max	°C		-10-46	
Outdoor operating limits - HEATING	min-max	°C		-15-24	

The data in this catalogue is purely indicative as the data may vary. Please be advised to check the accuracy of the data with the supplier before purchasing products.



Commercial R32 DUCTED MEDIUM PRESSURE

COMPACT DESIGN

The unit has a thickness of 248 mm which allows better adaptation and ease of installation.



CONDENSATE DRAIN

The medium-pressure ducted units includes a condensate drain pump as standard. This guarantees a maximum prevalence of 600 mm measured from the base of the machine. There is the possibility of performing condensate drain by gravity (reversible on both sides).

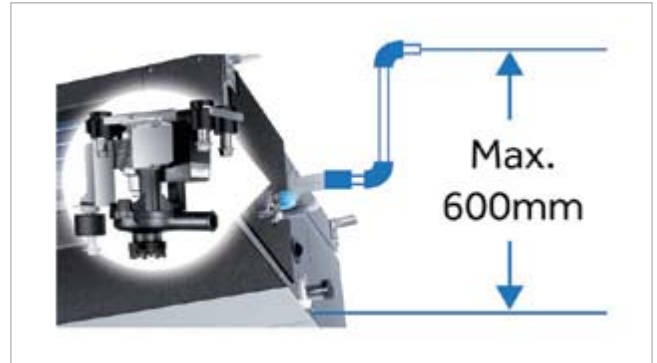

EASY INSTALLATION

- The connection of electrical cables is now possible through only one screw.
- The ducted units have two options for connecting the air extraction channel: rear or lower.



WiFi

Besides normal wired/infrared control, Haier supplies Smart Control from hOn APP. Including the on/off, operation mode selection, fan speed temperature, and air flow adjustment, schedule, UV function and steri-clean 56°C, etc.



FRESH AIR

Air exchange allows introduction of clean air into the room.

UVC Sterilisation

The built-in LED UV lights kill airborne hazards when the air circulates from air inlet, ensuring the clean air out.



Flexible air distribution

The ducted units satisfy multiple installation solutions (circular or rectangular channels).

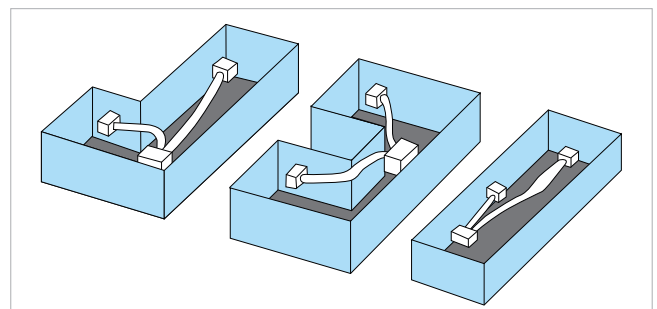

Commercial R32 DUCTED MEDIUM PRESSURE



AD35 - AD50 - AD71

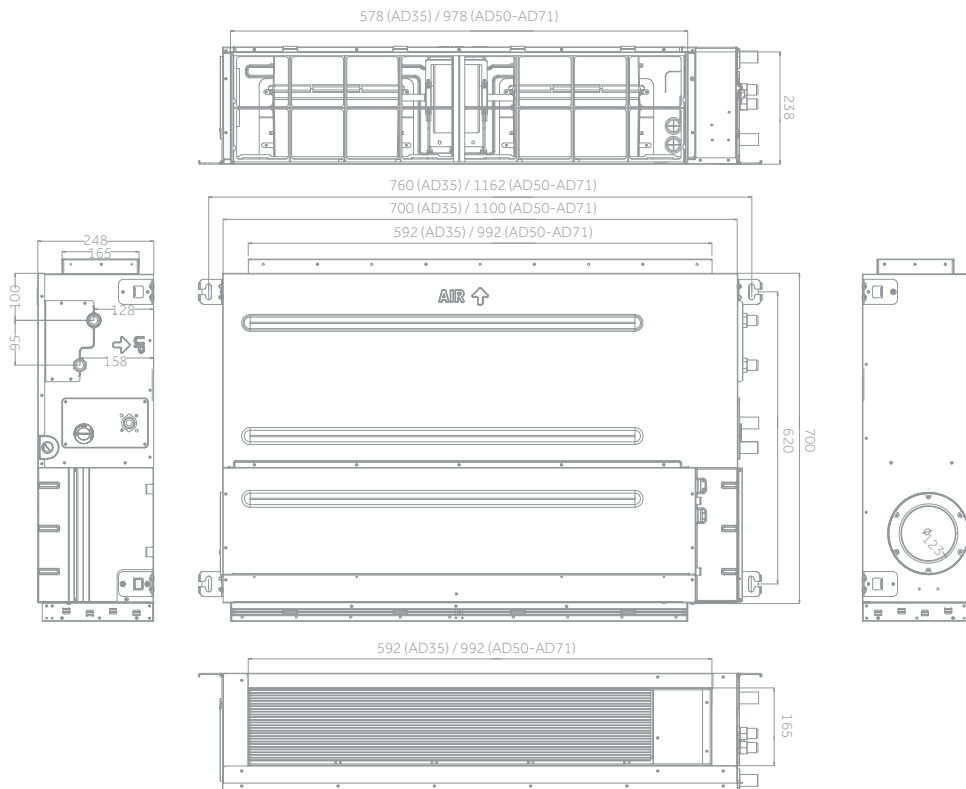

1U35

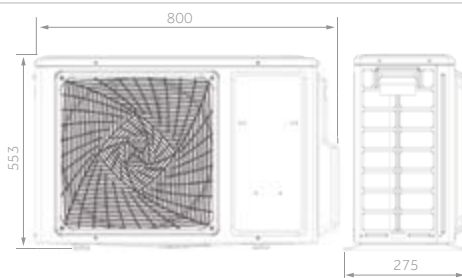

1U50

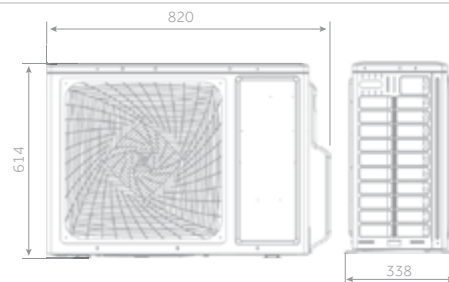

1U71

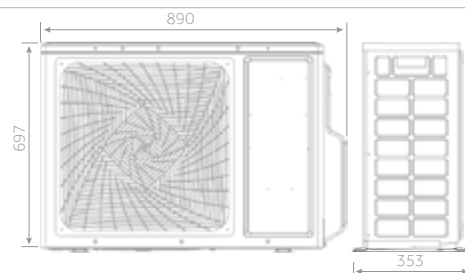

3,5 kW

5,0 kW

7,1 kW

Commercial R32 DUCTED MEDIUM PRESSURE

Haier

COMMERCIAL R32

3,5 kW

5,0 kW

7,1 kW

OPTIONAL CONTROL



Silence

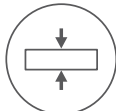

Compact Design



Fresh Air



Condensate
Drain Pump



Flexible
Installation



Wi-Fi Optional



AD71S2SM3FA

- Low noise level
- Compact design
- 'Fresh air' knockout is incorporated in the chassis to allow fresh air introduction of up to 20% of nominal unit air flow without compromising the cooling capacity. More than 20% of the air conditioner's thermal cooling capacity is penalise.
- Condensate drain pump

Indoor Unit	Model		AD35S2SM3FA	AD50S2SM3FA	AD71S2SM3FA
Outdoor Unit	Model		1U35S2SM1FA-2	1U50S2S2FA	1U71S2SR2FA
Performance data					
Output power - COOLING	nom (min-max)	kW	3,50 (0,90-4,50)	5,00 (1,80-6,00)	7,10 (2,00-8,20)
Output power - HEATING	nom (min-max)	kW	4,00 (1,00-4,80)	6,00 (2,00-6,20)	7,50 (2,50-8,50)
Absorbed power - COOLING	nom (min-max)	kW	1,08 (0,28-1,80)	1,55 (0,55-2,00)	2,20 (0,50-3,00)
Absorbed power - HEATING	nom (min-max)	kW	1,08 (0,28-1,80)	1,48 (0,60-2,00)	2,02 (0,60-3,00)
Energy class	EER	W/W	3,23	3,23	3,23
	COP	W/W	3,71	3,71	3,71
COOLING Pdesign	35 °C	kW	3,50	5,00	7,10
HEATING Pdesign	(-10 °C)	kW	2,70	4,50	5,00
Energy class	SEER		6,10 (A++)	6,10 (A++)	6,10 (A++)
	SCOP		3,80 (A)	3,80 (A)	3,80 (A)
Annual Energy Consumption - COOLING		kWh/a	215	291	406
Annual Energy Consumption - HEATING		kWh/a	1020	1782	1827
Indoor Unit					
Power supply		Ph/V/Hz	1/220-240/50/60	1/220-240/50/60	1/220-240/50/60
Treated air volume	(H/M/L/Q)	m ³ /h	840/720/600/450	1020/900/780/550	1440/1260/1100/900
External static pressure		Pa	25(default)/37/50/70/90/100/110/120/130/150		
High sound power		dB	55	56	58
Sound pressure		dB(A)	41/35/28/26	43/37/30/28	44/41/39/36
Net dimensions	WxDxH	mm	700x700x248	1100x700x248	1100x700x248
Packaging dimensions	WxDxH	mm	914x866x318	1316x866x318	1316x866x318
Net/gross weight		kg	26,0/30,0	31,0/35,0	31,0/35,0
Outdoor Unit					
Power supply		Ph/V/Hz	1/220-240/50	1/220-240/50	1/220-240/50/60
Power cable		N x mm ²	3 x 1,5	3 x 1,5	3 x 4,0
Interconnection cable		N x mm ²	4 x 1,0	4 x 1,0	4 x 2,5
Sound power	H	dB	61	63	67
Sound pressure	H	dB(A)	48	51	54
Running current cooling/heating	Max	A	8,0	9,5	13,1
Starting current cooling/heating	Max	A	2,0	2,0	2,0
Net dimensions	WxDxH	mm	800x275x553	820x338x614	890x353x697
Packaging dimensions	WxDxH	mm	908x405x625	993x413x685	1046x460x780
Net/gross weight		kg	30,0/32,9	37,8/41,5	45,0/50,0
Compressor type			Rotary inverter	Twin rotary inverter	Twin rotary inverter
Installation data					
Refrigerant			R32	R32	R32
Liquid pipe	∅	mm (inch)	6,35 (1/4)	6,35 (1/4)	9,52 (3/8)
Gas pipe	∅	mm (inch)	9,52 (3/8)	12,70 (1/2)	15,88 (5/8)
Standard pipe length without refrigerant charge		m	7	7	10
Maximum pipe length		m	15	25	50
Maximum IU - OU elevation		m	10	15	30
Refrigerant charge in the factory		kg	0,78	0,95	1,30
Refrigerant charge in the factory		TCO ₂ eq	0,53	0,64	0,88
Additional ref. charge over std length		g/m	20	20	45
Outdoor operating limits - COOLING	min-max	°C		-10-46	
Outdoor operating limits - HEATING	min-max	°C		-15-24	

Commercial R32 DUCTED MEDIUM PRESSURE



AD35 - AD50 - AD71

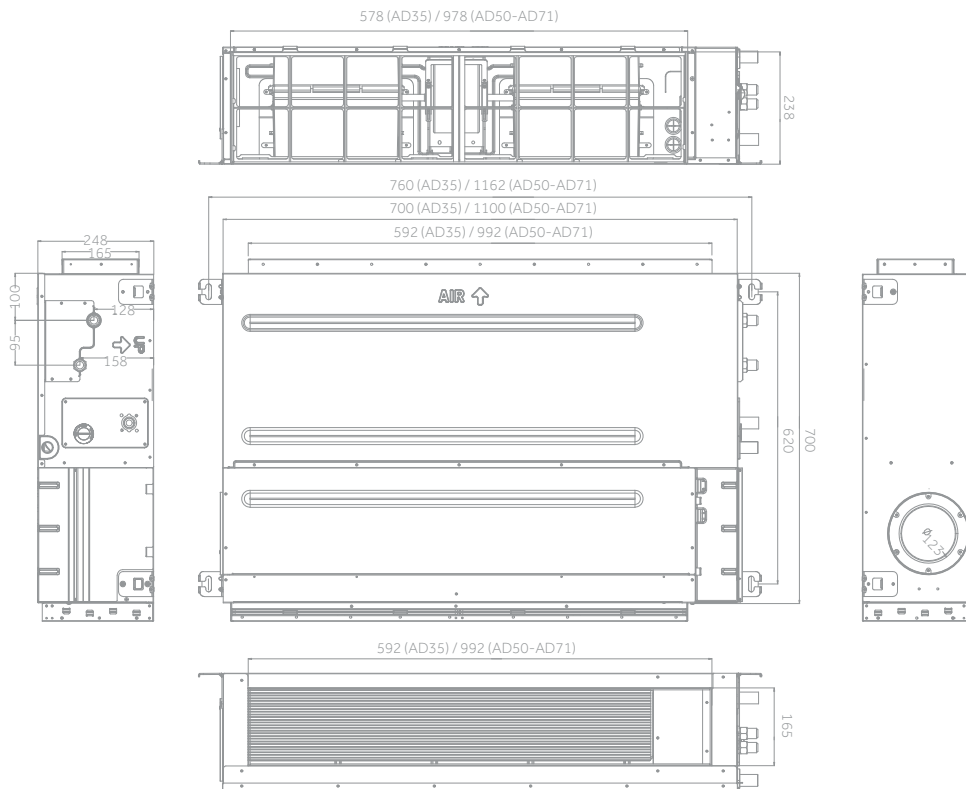

1U35

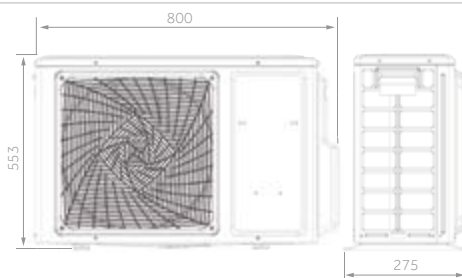

1U50

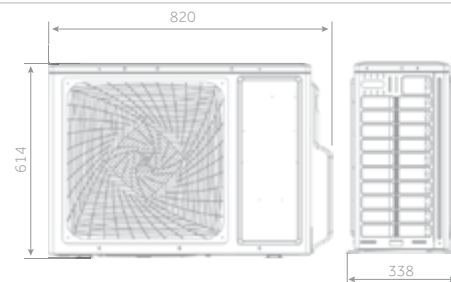

1U71

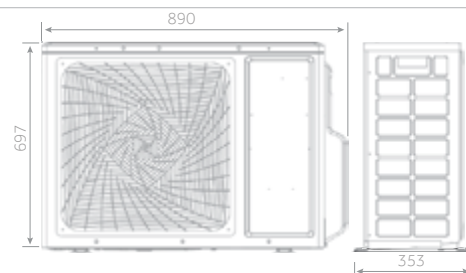

3,5 kW

5,0 kW

7,1 kW

Commercial R32 DUCTED MEDIUM PRESSURE

NEW

Haier

3,5 kW

5,0 kW

7,1 kW

OPTIONAL CONTROL



Silence

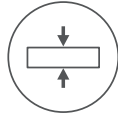

Compact Design



Fresh Air



Condensate
Drain Pump



Flexible
Installation

NEW



UVC Sterilisation

NEW



Wi-Fi control
integrated



AD71S2SM3FA

- Low noise level
- Compact design
- 'Fresh air' knockout is incorporated in the chassis to allow fresh air introduction of up to 20% of nominal unit air flow without compromising the cooling capacity. More than 20% of the air conditioner's thermal cooling capacity is penalise.
- Condensate drain pump
- Wi-Fi control integrated
- UVC Sterilisation

Indoor Unit	Model		AD35S2SM3FA(H)	AD50S2SM3FA(H)	AD71S2SM3FA(H)	AD105S2SM3FA(H)	AD105S2SM3FA(H)
Outdoor Unit	Model		1U35S2SM1FA-2	1U50S2S2FA	1U71S2SR2FA	1U105S2SS2FA	1U105S2SS1FB
Performance data							
Output power - COOLING	nom (min-max)	kW	3,50 (0,90-4,50)	5,00 (1,80-6,00)	7,10 (2,00-8,20)	9,50 (2,50-10,00)	9,50 (2,50-10,00)
Output power - HEATING	nom (min-max)	kW	4,00 (1,00-4,80)	6,00 (2,00-6,20)	7,50 (2,50-8,50)	10,20 (3,00-10,50)	10,50 (3,00-11,00)
Absorbed power - COOLING	nom (min-max)	kW	1,08 (0,28-1,80)	1,55 (0,55-2,00)	2,20 (0,50-3,00)	3,16 (0,50-4,00)	3,27 (0,50-4,00)
Absorbed power - HEATING	nom (min-max)	kW	1,08 (0,28-1,80)	1,48 (0,60-2,00)	2,02 (0,60-3,00)	2,91 (0,50-4,00)	3,00 (0,50-4,00)
Energy class	EER	W/W	3,23	3,23	3,23	3,01	2,90
	COP	W/W	3,71	3,71	3,71	3,50	3,50
COOLING Pdesign	35 °C	kW	3,50	5,00	7,10	9,50	9,50
HEATING Pdesign	(-10 °C)	kW	2,70	4,50	5,00	7,20	6,00
Energy class	SEER		6,10 (A++)	6,10 (A++)	6,10 (A++)	6,10 (A++)	6,00 (A+)
	SCOP		3,80 (A)	3,80 (A)	3,80 (A)	3,80 (A)	3,91 (A)
Annual Energy Consumption - COOLING		kWh/a	215	291	406	544	569
Annual Energy Consumption - HEATING		kWh/a	1020	1782	1827	2792	2094
Indoor Unit							
Power supply		Ph/V/Hz	1/220-240/50/60	1/220-240/50/60	1/220-240/50/60	1/220-240/50/60	1/220-240/50/60
Treated air volume	(H/M/L/Q)	m ³ /h	840/720/600/450	1020/900/780/550	1440/1260/1100/900	1600/1480/1360/1240	1600/1480/1360/1240
External static pressure		Pa	25(default)/37/50/70/90/100/110/120/130/150				
High sound power		dB	55	56	58	61	64
Sound pressure		dB(A)	41/35/28/26	43/37/30/28	44/41/39/36	47/44/40/37	47/44/40/37
Net dimensions	WxDxH	mm	700x700x248	1100x700x248	1100x700x248	1500x700x248	1500x700x248
Packaging dimensions	WxDxH	mm	914x866x318	1316x866x318	1316x866x318	1711x870x325	1711x870x325
Net/gross weight		kg	26,0/30,0	31,0/35,0	31,0/35,0	46,0/55,0	46,0/55,0
Outdoor Unit							
Power supply		Ph/V/Hz	1/220-240/50	1/220-240/50	1/220-240/50/60	1/220-240/50/60	3/380-415/50/60
Power cable		N x mm ²	3 x 1,5	3 x 1,5	3 x 4,0	3 x 4,0	3 x 4,0
Interconnection cable		N x mm ²	4 x 1,0	4 x 1,0	4 x 2,5	4 x 2,5	4 x 2,5
Sound power	H	dB	61	63	67	66	68
Sound pressure	H	dB(A)	48	51	54	53	54
Running current cooling/heating	Max	A	8,0	9,5	13,1	16,5	16,5
Starting current cooling/heating	Max	A	2,0	2,0	2,0	3,0	3,0
Net dimensions	WxDxH	mm	800x275x553	820x338x614	890x353x697	920*372*760	920*372*760
Packaging dimensions	WxDxH	mm	908x405x625	993x413x685	1046x460x780	1036*478*820	1085x485x830
Net/gross weight		kg	30,0/32,9	37,8/41,5	45,0/50,0	60,0/65,0	61,0/66,0
Compressor type			Rotary inverter	Twin rotary inverter	Twin rotary inverter	Twin rotary inverter	Twin rotary inverter
Installation data							
Refrigerant			R32	R32	R32	R32	R32
Liquid pipe	Ø	mm (inch)	6,35 (1/4)	6,35 (1/4)	9,52 (3/8)	9,52 (3/8)	9,52 (3/8)
Gas pipe	Ø	mm (inch)	9,52 (3/8)	12,70 (1/2)	15,88 (5/8)	15,88 (5/8)	15,88 (5/8)
Standard pipe length without refrigerant charge		m	7	7	10	30	30
Maximum pipe length		m	15	25	50	50	50
Maximum IU - OU elevation		m	10	15	30	30	30
Refrigerant charge in the factory		kg	0,78	0,95	1,30	1,70	1,70
Refrigerant charge in the factory		TCO ₂ eq	0,53	0,64	0,88	1,15	1,15
Additional ref. charge over std length		g/m	20	20	45	45	45
Outdoor operating limits - COOLING	min-max	°C	-10-46				
Outdoor operating limits - HEATING	min-max	°C	-15-24				

The data in this catalogue is purely indicative as the data may vary. Please be advised to check the accuracy of the data with the supplier before purchasing products.

Commercial R32 DUCTED MEDIUM PRESSURE



AD35 - AD50 - AD71

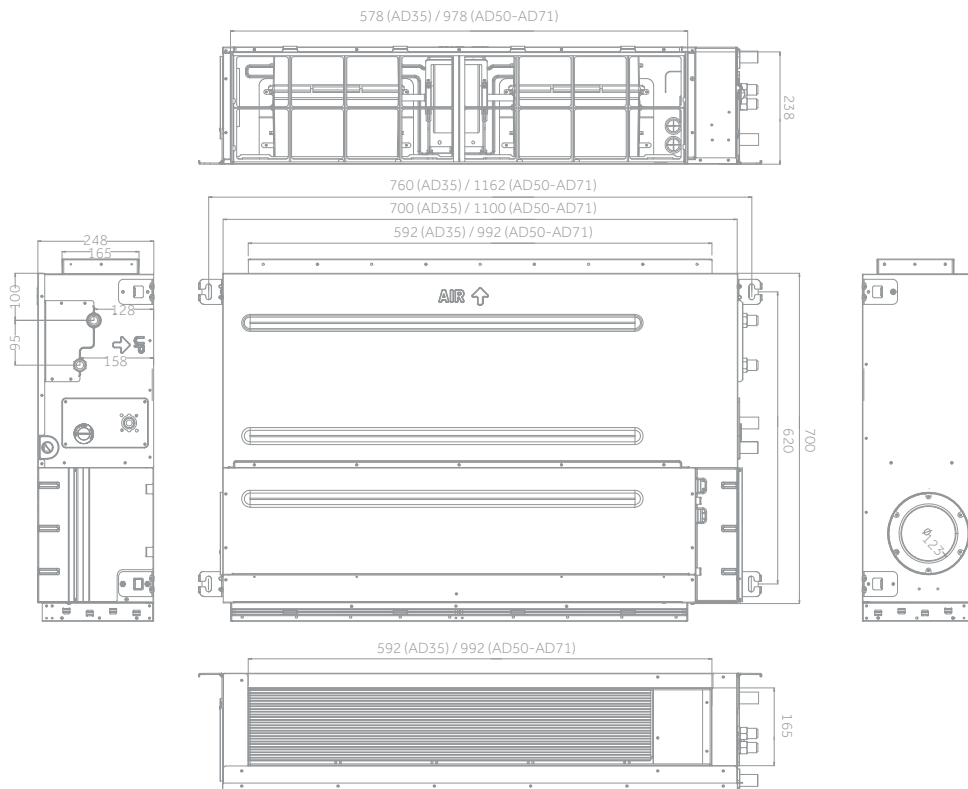

1U35

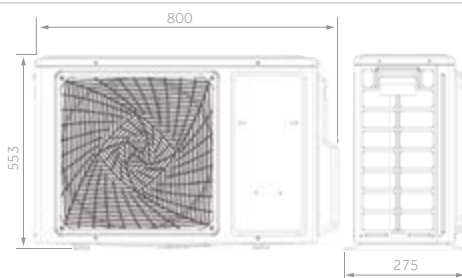

1U50

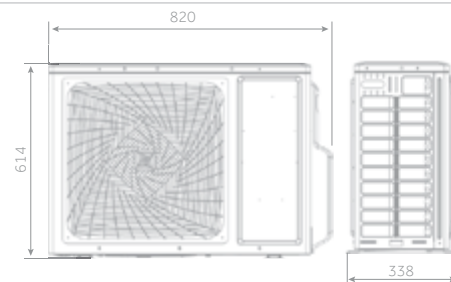

1U71

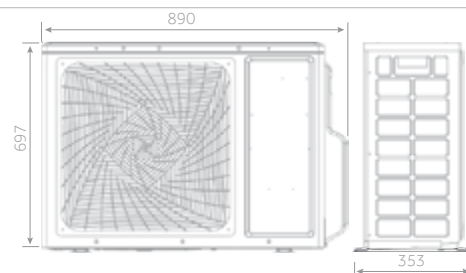

3,5 kW

5,0 kW

7,1 kW

Commercial R32 DUCTED MEDIUM PRESSURE

Haier

3,5 kW

5,0 kW

7,1 kW

OPTIONAL CONTROL

COMMERCIAL R32



Silence

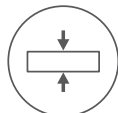

Compact Design



Fresh Air



Condensate
Drain Pump



Flexible
Installation



Wi-Fi Optional



AD71S2SM3FA

- Low noise level
- Compact design
- 'Fresh air' knockout is incorporated in the chassis to allow fresh air introduction of up to 20% of nominal unit air flow without compromising the cooling capacity. More than 20% of the air conditioner's thermal cooling capacity is penalise.
- Condensate drain pump

Indoor Unit	Model		AD105S2SM3FA	AD105S2SM3FA	AD125S2SM3FA	AD125S2SM3FA
Outdoor Unit	Model		1U105S2SS2FA	1U105S2SS1FB	1U125S2SN2FA	1U125S2SN2FB
Performance data						
Output power - COOLING	nom (min-max)	kW	9,50 (2,50-10,00)	9,50 (2,50-10,00)	12,30 (3,00-13,00)	12,40 (3,00-13,00)
Output power - HEATING	nom (min-max)	kW	10,20 (3,00-10,50)	10,50 (3,00-11,00)	12,70 (3,50-13,50)	12,80 (3,50-13,50)
Absorbed power - COOLING	nom (min-max)	kW	3,16 (0,50-4,00)	3,27 (0,50-4,00)	4,60 (1,00-6,00)	4,51 (1,00-6,00)
Absorbed power - HEATING	nom (min-max)	kW	2,91 (0,50-4,00)	3,00 (0,50-4,00)	3,93 (1,00-6,00)	3,87 (1,00-6,00)
Energy class	EER	W/W	3,01	2,90	2,67	2,75
	COP	W/W	3,50	3,50	3,23	3,31
COOLING Pdesign	35 °C	kW	9,50	9,50	12,30	12,40
HEATING Pdesign	(-10 °C)	kW	7,20	6,00	8,00	8,00
Energy class	SEER		6,10 (A++)	6,00 (A+)	5,72 (A+)	5,85 (A+)
	SCOP		3,80 (A)	3,91 (A)	3,93 (A)	3,96 (A)
Annual Energy Consumption - COOLING		kWh/a	544	569	735	718
Annual Energy Consumption - HEATING		kWh/a	2792	2094	3032	3003
Indoor Unit						
Power supply		Ph/V/Hz	1/220-240/50/60	1/220-240/50/60	1/220-240/50/60	1/220-240/50/60
Treated air volume	(H/M/L/Q)	m ³ /h	1600/1480/1360/1240	1600/1480/1360/1240	2250/1960/1680/1500	2250/1960/1680/1500
External static pressure		Pa	25/37(default)/50/70/90/100/110/120/130/150			
High sound power		dB	61	64	65	65
Sound pressure		dB(A)	47/44/40/37	47/44/40/37	48/45/42/39	48/45/42/39
Net dimensions	WxDxH	mm	1500x700x248	1500x700x248	1500x700x248	1500x700x248
Packaging dimensions	WxDxH	mm	1711x870x325	1711x870x325	1711x870x325	1711x870x325
Net/gross weight		kg	46,0/55,0	46,0/55,0	52,0/62,0	52,0/62,0
Outdoor Unit						
Power supply		Ph/V/Hz	1/220-240/50/60	3/380-415/50/60	1/220-240/50/60	3/380-415/50/60
Power cable		N x mm ²	3 x 4,0	5 x 4,0	3 x 6,0	5 x 4,0
Interconnection cable		N x mm ²	4 x 2,5	4 x 2,5	4 x 2,5	4 x 2,5
Sound power	H	dB	66	68	72	72
Sound pressure	H	dB(A)	53	54	58	58
Running current cooling/heating	Max	A	16,5	6,8	26,0	10,0
Starting current cooling/heating	Max	A	3,0	1,0	4,0	2,0
Net dimensions	WxDxH	mm	920*372*760	920*372*760	950x370x965	950x370x965
Packaging dimensions	WxDxH	mm	1036*478*820	1085x485x830	1050x485x1130	1050x485x1130
Net/gross weight		kg	60,0/65,0	61,0/66,0	84,0/89,0	85,0/90,0
Compressor type			Twin rotary inverter	Twin rotary inverter	Twin rotary inverter	Twin rotary inverter
Installation data						
Refrigerant			R32	R32	R32	R32
Liquid pipe	∅	mm (inch)	9,52 (3/8)	9,52 (3/8)	9,52 (3/8)	9,52 (3/8)
Gas pipe	∅	mm (inch)	15,88 (5/8)	15,88 (5/8)	15,88 (5/8)	15,88 (5/8)
Standard pipe length without refrigerant charge		m	30	30	30	30
Maximum pipe length		m	50	50	50	50
Maximum IU - OU elevation		m	30	30	30	30
Refrigerant charge in the factory		kg	1,70	1,70	2,30	2,30
Refrigerant charge in the factory		TCO _{2eq}	1,15	1,15	1,55	1,55
Additional ref. charge over std length		g/m	45	45	45	45
Outdoor operating limits - COOLING	min-max	°C	-10-46			
Outdoor operating limits - HEATING	min-max	°C	-15-24			

Commercial R32 DUCTED MEDIUM PRESSURE



AD105 - AD125

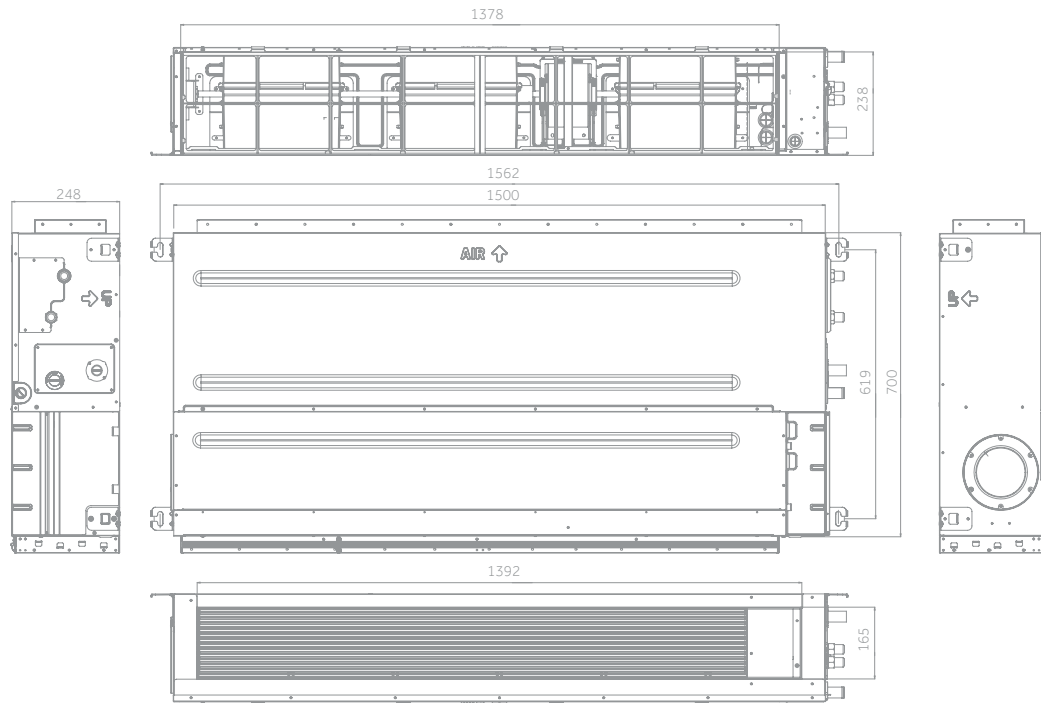

1U105

1U125

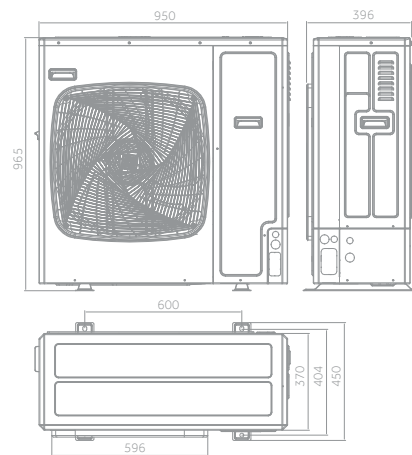
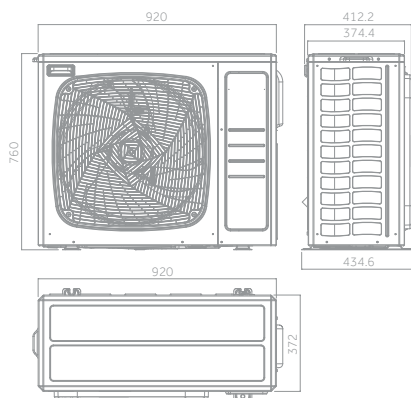

10,5 kW



12,5 kW

Commercial R32 DUCTED MEDIUM PRESSURE

Haier

10,5 kW

12,5 kW

OPTIONAL CONTROL

COMMERCIAL R32



Silence

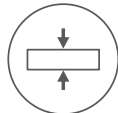

Compact Design



Fresh Air



Condensate
Drain Pump



Flexible
Installation



Wi-Fi Optional



- Low noise level
- Compact design
- 'Fresh air' knockout is incorporated in the chassis to allow fresh air introduction of up to 20% of nominal unit air flow without compromising the cooling capacity. More than 20% of the air conditioner's thermal cooling capacity is penalise.
- Condensate drain pump

Indoor Unit	Model		AD105S2SM3FA	AD105S2SM3FA	AD125S2SM3FA	AD125S2SM3FA
Outdoor Unit	Model		1U105S2SS2FA	1U105S2SS1FB	1U125S2SN2FA	1U125S2SN2FB
Performance data						
Output power - COOLING	nom (min-max)	kW	9,50 (2,50-10,00)	9,50 (2,50-10,00)	12,30 (3,00-13,00)	12,40 (3,00-13,00)
Output power - HEATING	nom (min-max)	kW	10,20 (3,00-10,50)	10,50 (3,00-11,00)	12,70 (3,50-13,50)	12,80 (3,50-13,50)
Absorbed power - COOLING	nom (min-max)	kW	3,16 (0,50-4,00)	3,27 (0,50-4,00)	4,60 (1,00-6,00)	4,51 (1,00-6,00)
Absorbed power - HEATING	nom (min-max)	kW	2,91 (0,50-4,00)	3,00 (0,50-4,00)	3,93 (1,00-6,00)	3,87 (1,00-6,00)
Energy class	EER	W/W	3,01	2,90	2,67	2,75
	COP	W/W	3,50	3,50	3,23	3,31
COOLING Pdesign	35 °C	kW	9,50	9,50	12,30	12,40
HEATING Pdesign	(-10 °C)	kW	7,20	6,00	8,00	8,00
Energy class	SEER		6,10 (A++)	6,00 (A+)	5,72 (A+)	5,85 (A+)
	SCOP		3,80 (A)	3,91 (A)	3,93 (A)	3,96 (A)
Annual Energy Consumption - COOLING		kWh/a	544	569	735	718
Annual Energy Consumption - HEATING		kWh/a	2792	2094	3032	3003
Indoor Unit						
Power supply		Ph/V/Hz	1/220-240/50/60	1/220-240/50/60	1/220-240/50/60	1/220-240/50/60
Treated air volume	(H/M/L/Q)	m ³ /h	1600/1480/1360/1240	1600/1480/1360/1240	2250/1960/1680/1500	2250/1960/1680/1500
External static pressure		Pa	25/37(default)/50/70/90/100/110/120/130/150			
High sound power		dB	61	64	65	65
Sound pressure		dB(A)	47/44/40/37	47/44/40/37	48/45/42/39	48/45/42/39
Net dimensions	WxDxH	mm	1500x700x248	1500x700x248	1500x700x248	1500x700x248
Packaging dimensions	WxDxH	mm	1711x870x325	1711x870x325	1711x870x325	1711x870x325
Net/gross weight		kg	46,0/55,0	46,0/55,0	52,0/62,0	52,0/62,0
Outdoor Unit						
Power supply		Ph/V/Hz	1/220-240/50/60	3/380-415/50/60	1/220-240/50/60	3/380-415/50/60
Power cable		N x mm ²	3 x 4,0	5 x 4,0	3 x 6,0	5 x 4,0
Interconnection cable		N x mm ²	4 x 2,5	4 x 2,5	4 x 2,5	4 x 2,5
Sound power	H	dB	66	68	72	72
Sound pressure	H	dB(A)	53	54	58	58
Running current cooling/heating	Max	A	16,5	6,8	26,0	10,0
Starting current cooling/heating	Max	A	3,0	1,0	4,0	2,0
Net dimensions	WxDxH	mm	920*372*760	920*372*760	950x370x965	950x370x965
Packaging dimensions	WxDxH	mm	1036*478*820	1085x485x830	1050x485x1130	1050x485x1130
Net/gross weight		kg	60,0/65,0	61,0/66,0	84,0/89,0	85,0/90,0
Compressor type			Twin rotary inverter	Twin rotary inverter	Twin rotary inverter	Twin rotary inverter
Installation data						
Refrigerant			R32	R32	R32	R32
Liquid pipe	∅	mm (inch)	9,52 (3/8)	9,52 (3/8)	9,52 (3/8)	9,52 (3/8)
Gas pipe	∅	mm (inch)	15,88 (5/8)	15,88 (5/8)	15,88 (5/8)	15,88 (5/8)
Standard pipe length without refrigerant charge		m	30	30	30	30
Maximum pipe length		m	50	50	50	50
Maximum IU - OU elevation		m	30	30	30	30
Refrigerant charge in the factory		kg	1,70	1,70	2,30	2,30
Refrigerant charge in the factory		TCO ₂ eq	1,15	1,15	1,55	1,55
Additional ref. charge over std length		g/m	45	45	45	45
Outdoor operating limits - COOLING	min-max	°C	-10-46			
Outdoor operating limits - HEATING	min-max	°C	-15-24			

Commercial R32 DUCTED MEDIUM PRESSURE



AD140 - AD160

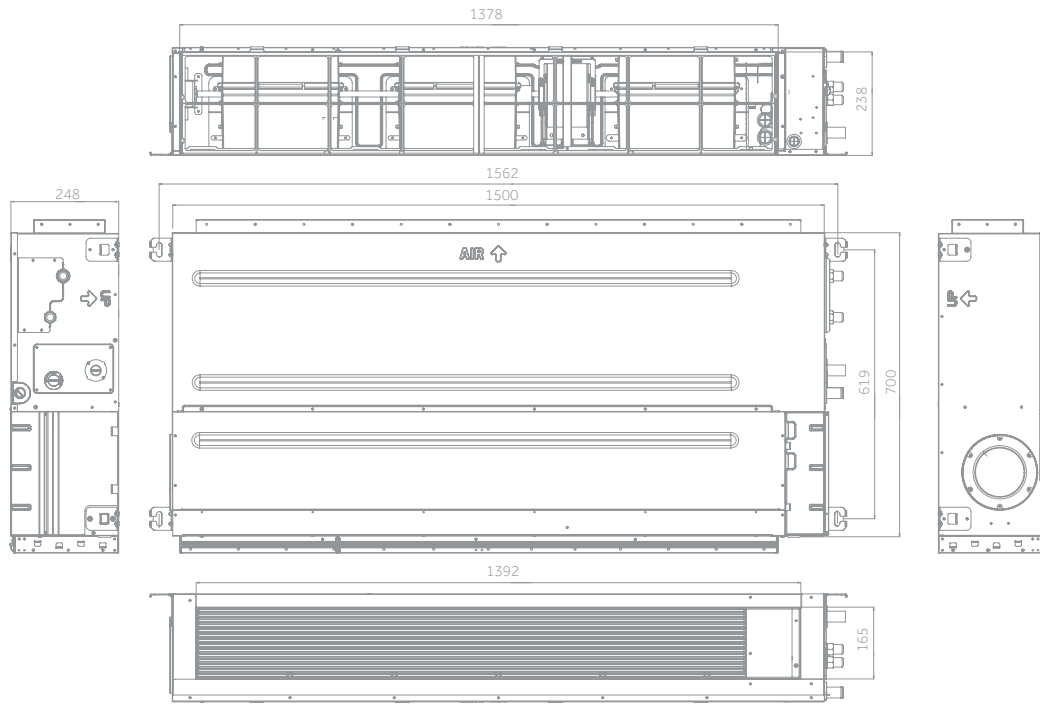

1U140

1U140 - 1U160

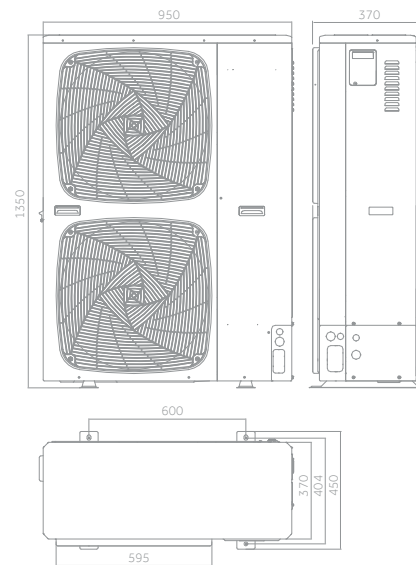
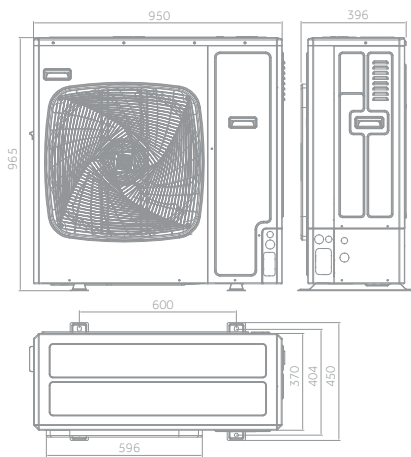

14,0 kW



14,0 kW



16,0 kW

Commercial R32 DUCTED MEDIUM PRESSURE

Haier

14,0 kW

16,0 kW

OPTIONAL CONTROL

COMMERCIAL R32



Silence

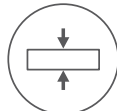

Compact Design



Fresh Air



Condensate
Drain Pump



Flexible
Installation



Wi-Fi Optional



- Low noise level
- Compact design
- 'Fresh air' knockout is incorporated in the chassis to allow fresh air introduction of up to 20% of nominal unit air flow without compromising the cooling capacity. More than 20% of the air conditioner's thermal cooling capacity is penalise.
- Condensate drain pump

Indoor Unit	Model		AD140S2SM3FA	AD140S2SM3FA	AD140S2SM3FA	AD140S2SM3FA	AD160S2SM3FA
Outdoor Unit	Model		1U140S2SN1FA	1U140S2SN1FB	1U140S2SP2FA	1U140S2SP2FB	1U160S2SP1FB
Performance data							
Output power - COOLING	nom (min-max)	kW	13,40 (3,50-14,00)	13,40 (3,50-14,00)	13,40 (4,00-15,00)	13,40 (4,00-15,00)	16,00 (4,50-16,50)
Output power - HEATING	nom (min-max)	kW	15,00 (4,00-15,50)	15,00 (4,00-15,50)	15,00 (4,50-16,00)	15,00 (4,50-16,00)	17,00 (5,00-18,00)
Absorbed power - COOLING	nom (min-max)	kW	5,28 (1,00-6,50)	5,18 (1,00-6,50)	4,17 (1,00-6,00)	4,15 (1,00-6,00)	5,48 (1,00-6,50)
Absorbed power - HEATING	nom (min-max)	kW	4,92 (1,00-6,50)	4,79 (1,00-6,50)	4,04 (1,00-6,00)	4,02 (1,00-6,00)	4,82 (1,00-6,50)
Energy class	EER	W/W	2,54	2,59	3,21	3,23	2,92
	COP	W/W	3,05	3,13	3,71	3,73	3,53
COOLING Pdesign	35 °C	kW	13,40	13,40	13,40	13,40	16,00
HEATING Pdesign	(-10 °C)	kW	8,50	8,50	11,00	11,00	11,00
Energy class	SEER		5,62 (A+)	5,64 (A+)	6,16 (A++)	6,19 (A++)	5,94 (A+)
	SCOP		3,93 (A)	3,96 (A)	4,06 (A+)	4,06 (A+)	4,06 (A+)
Annual Energy Consumption - COOLING		kWh/a	835	832	761	758	943
Annual Energy Consumption - HEATING		kWh/a	3032	3003	3796	3798	3798
Indoor Unit							
Power supply		Ph/V/Hz	1/220-240/50/60	1/220-240/50/60	1/220-240/50/60	1/220-240/50/60	1/220-240/50/60
Treated air volume	(H/M/L/Q)	m ³ /h	2500/2160/1780/1500	2500/2160/1780/1500	2500/2160/1780/1500	2500/2160/1780/1500	2500/2160/1780/1500
External static pressure		Pa	25/37(default)/50/70/90/100/110/120/130/150				
High sound power		dB	66	66	66	66	67
Sound pressure		dB(A)	48/45/42/39	48/45/42/39	48/45/42/39	48/45/42/39	48/45/42/39
Net dimensions	WxDxH	mm	1500x700x248	1500x700x248	1500x700x248	1500x700x248	1500x700x248
Packaging dimensions	WxDxH	mm	1711x870x325	1711x870x325	1711x870x325	1711x870x325	1711x870x325
Net/gross weight		kg	52,0/62,0	52,0/62,0	52,0/62,0	52,0/62,0	48,0/57,0
Outdoor Unit							
Power supply		Ph/V/Hz	1/220-240/50/60	3/380-415/50/60	1/220-240/50/60	3/380-415/50/60	3/380-415/50/60
Power cable		N x mm ²	3 x 6,0	5 x 4,0	3 x 6,0	5 x 4,0	5 x 4,0
Interconnection cable		N x mm ²	4 x 2,5	4 x 2,5	4 x 2,5	4 x 2,5	4 x 2,5
Sound power	H	dB	72	72	70	70	72
Sound pressure	H	dB(A)	58	58	53	53	58
Running current cooling/heating	Max	A	30,0	10,0	32,0	10,0	10,0
Starting current cooling/heating	Max	A	5,0	2,0	6,0	2,0	2,0
Net dimensions	WxDxH	mm	950x370x965	950x370x965	950x370x1350	950x370x1350	950x370x1350
Packaging dimensions	WxDxH	mm	1050x485x1130	1050x485x1130	1050x485x1500	1050x485x1500	1050x485x1500
Net/gross weight		kg	84,0/89,0	85,0/90,0	105,0/118,0	101,0/116,0	101,0/116,0
Compressor type			Twin rotary inverter	Twin rotary inverter	Twin rotary inverter	Twin rotary inverter	Twin rotary inverter
Installation data							
Refrigerant			R32	R32	R32	R32	R32
Liquid pipe	∅	mm (inch)	9,52 (3/8)	9,52 (3/8)	9,52 (3/8)	9,52 (3/8)	9,52 (3/8)
Gas pipe	∅	mm (inch)	15,88 (5/8)	15,88 (5/8)	15,88 (5/8)	15,88 (5/8)	19,05 (3/4)
Standard pipe length without refrigerant charge		m	30	30	30	30	30
Maximum pipe length		m	70	70	70	70	70
Maximum IU - OU elevation		m	30	30	30	30	30
Refrigerant charge in the factory		kg	2,30	2,30	2,90	3,50	3,50
Refrigerant charge in the factory		TCO ₂ eq	1,55	1,55	1,96	2,36	2,36
Additional ref. charge over std length		g/m	45	45	45	45	45
Outdoor operating limits - COOLING	min-max	°C	-10-46				
Outdoor operating limits - HEATING	min-max	°C	-15-24				

**Commercial R32
DUCTED HIGH PRESSURE**

Commercial R32 DUCTED HIGH PRESSURE

FRESH AIR

Air exchange allows introduction of clean air into the room.



WI-FI (OPTIONAL)

Allows you to set the air conditioner remotely
Wi-Fi connection is possible with HI-WB201DEI module.



GREATER RANGE

The indoor unit can hold up to 3 fans so that air flow can be supplied evenly across the different ESPs, further increasing comfort.

210PA PRESSURE SETTING

The 210Pa ducted unit with 10 configurable steps allows for high design flexibility, thus meeting the duct installation requirements.

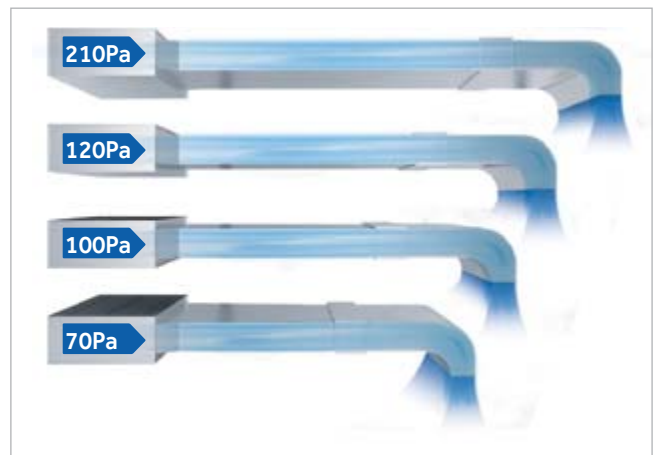

Flexible air distribution

The ducted units satisfy multiple installation solutions (circular or rectangular channels).

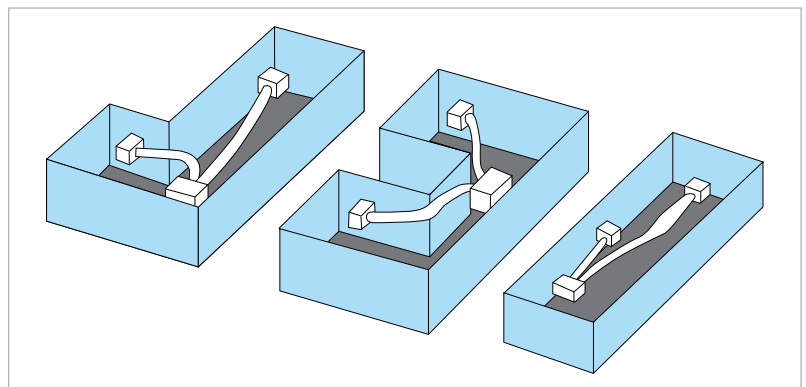

EASY INSTALLATION: PRESSURE ADJUSTABLE IN 10 STEPS

The pressure can be adjusted directly from the YR-E16B / YR-E17A remote controller.



Commercial R32 DUCTED HIGH PRESSURE



ADH125

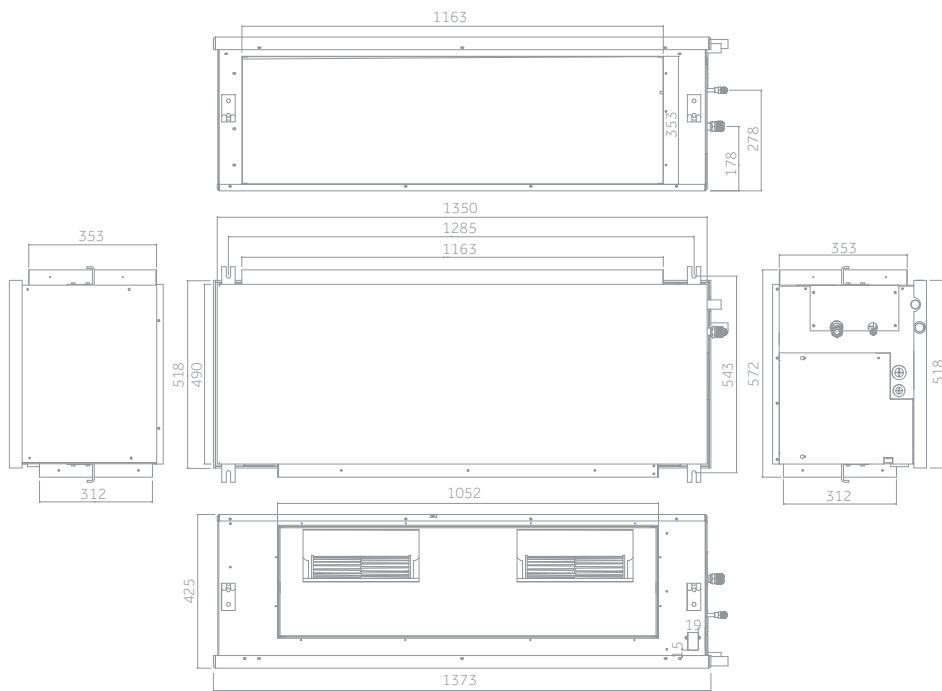

1U125

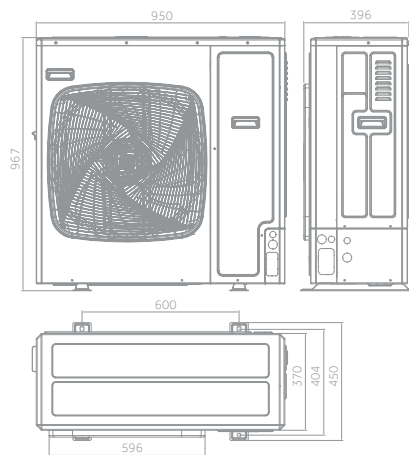

12,5

Commercial R32 DUCTED HIGH PRESSURE

Haier

12,5 kW

14,0 kW

OPTIONAL CONTROL

COMMERCIAL R32



Silence

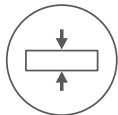

Compact Design



Fresh Air



On-Off Card



- Low noise level
- Compact design
- 'Fresh air' knockout is incorporated in the chassis to allow fresh air introduction of up to 20% of nominal unit air flow without compromising the cooling capacity. More than 20% of the air conditioner's thermal cooling capacity is penalise.
- Condensate drain by gravity - drain pump not provided

Indoor Unit	Model		ADH125H1ERG	ADH125H1ERG	ADH140H1ERG
Outdoor Unit	Model		1U125S2SN2FA	1U125S2SN2FB	1U140S2SN1FA
Performance data					
Output power - COOLING	nom (min-max)	kW	12,30 (3,00-13,00)	12,40 (3,00-13,00)	13,40 (3,50-14,00)
Output power - HEATING	nom (min-max)	kW	12,70 (3,50-13,50)	12,80 (3,50-13,50)	15,00 (4,00-15,50)
Absorbed power - COOLING	nom (min-max)	kW	4,47 (1,00-6,00)	4,56 (1,00-6,00)	4,75 (1,00-6,50)
Absorbed power - HEATING	nom (min-max)	kW	3,74 (1,00-6,00)	3,73 (1,00-6,00)	4,53 (1,00-6,50)
Energy class	EER	W/W	2,75	2,72	2,82
	COP	W/W	3,40	3,43	3,31
COOLING Pdesign	35 °C	kW	12,30	12,40	13,40
HEATING Pdesign	(-10 °C)	kW	8,00	8,00	8,50
Energy class	SEER		5,80 (A+)	5,90 (A+)	5,84 (A+)
	SCOP		3,94 (A)	3,97 (A)	3,94 (A)
Annual Energy Consumption - COOLING		kWh/a	713/745	700	803
Annual Energy Consumption - HEATING		kWh/a	3022	2998	3022
Indoor Unit					
Power supply		Ph/V/Hz	1/220-240/50/60	1/220-240/50/60	1/220-240/50/60
Treated air volume	(H/M/L/Q)	m ³ /h	3250/2750/2250/1750	3250/2750/2250/1750	3600/3100/2600/2100
External static pressure		Pa	37/50(default)/70/90/110 /130/150/170/190/210	37/50(default)/70/90/110 /130/150/170/190/210	37/50(default)/70/90/110 /130/150/170/190/210
High sound power		dB	64	64	65
Sound pressure		dB(A)	47/44/42/39	47/44/42/39	49/46/43/40
Net dimensions	WxDxH	mm	1350x490x425	1350x490x425	1350x490x425
Packaging dimensions	WxDxH	mm	1565x724x510	1565x724x510	1565x724x510
Net/gross weight		kg	61,0/72,0	61,0/72,0	61,0/72,0
Outdoor Unit					
Power supply		Ph/V/Hz	1 /220-240/ 50/60	3 /380-415/ 50/60	1 /220-240/ 50/60
Power cable		N x mm ²	3 x 6,0	5 x 4,0	3 x 6,0
Interconnection cable		N x mm ²	4 x 2,5	4 x 2,5	4 x 2,5
Sound power	H	dB	72	72	72
Sound pressure	H	dB(A)	58	58	58
Running current cooling/heating	Max	A	26,0	10,0	30,0
Starting current cooling/heating	Max	A	4,0	2,0	5,0
Net dimensions	WxDxH	mm	950x370x965	950x370x965	950x370x965
Packaging dimensions	WxDxH	mm	1050x485x1130	1050x485x1130	1050x485x1130
Net/gross weight		kg	84,0/89,0	85,0/90,0	84,0/89,0
Compressor type			Twin rotary inverter	Twin rotary inverter	Twin rotary inverter
Installation data					
Refrigerant			R32	R32	R32
Liquid pipe	∅	mm (inch)	9,52 (3/8)	9,52 (3/8)	9,52 (3/8)
Gas pipe	∅	mm (inch)	15,88 (5/8)	15,88 (5/8)	15,88 (5/8)
Standard pipe length without refrigerant charge		m	30	30	30
Maximum pipe length		m	50	50	70
Maximum IU - OU elevation		m	30	30	30
Refrigerant charge in the factory		kg	2,30	2,30	2,30
Refrigerant charge in the factory		TCO ₂ eq	1,55	1,55	1,55
Additional ref. charge over std length		g/m	45	45	45
Outdoor operating limits - COOL- ING	min-max	°C		-10~46	
Outdoor operating limits - HEATING	min-max	°C		-15~24	

Commercial R32 DUCTED HIGH PRESSURE



ADH140

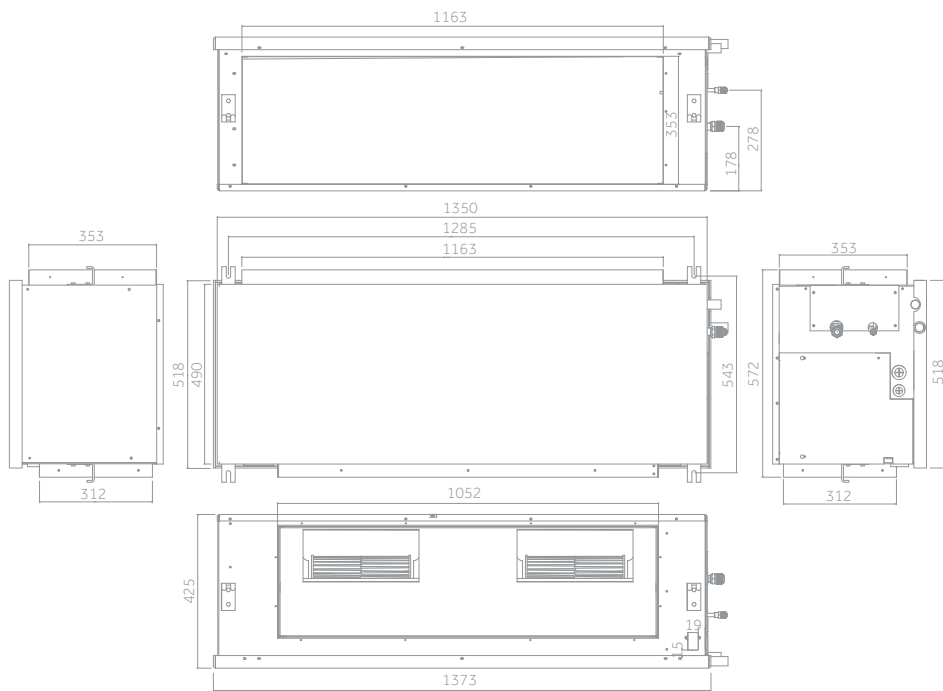

1U140

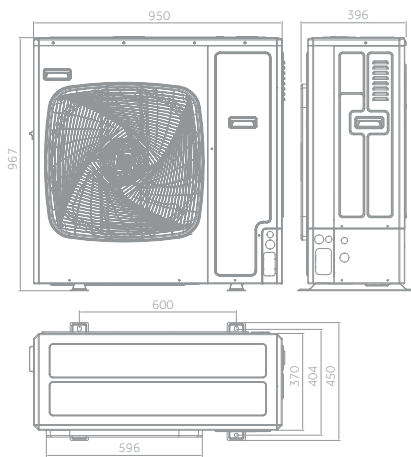

1U140

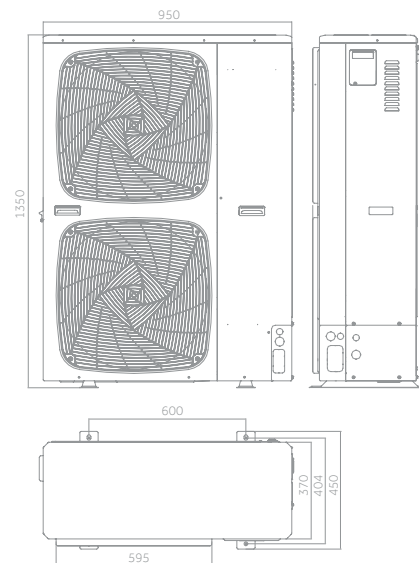

14,0 kW



14,0 kW

Commercial R32 DUCTED HIGH PRESSURE

Haier

14,0 kW

OPTIONAL CONTROL



Silence

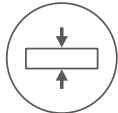

Compact Design



Fresh Air



On-Off Card



- Low noise level
- Compact design
- 'Fresh air' knockout is incorporated in the chassis to allow fresh air introduction of up to 20% of nominal unit air flow without compromising the cooling capacity. More than 20% of the air conditioner's thermal cooling capacity is penalise.
- Condensate drain by gravity - drain pump not provided

Indoor Unit	Model		ADH140H1ERG	ADH140H1ERG	ADH140H1ERG
Outdoor Unit	Model		1U140S2SN1FB	1U140S2SP2FA	1U140S2SP2FB
Performance data					
Output power - COOLING	nom (min-max)	kW	13,40 (3,50-14,00)	13,60 (4,00-15,00)	13,60 (4,00-15,00)
Output power - HEATING	nom (min-max)	kW	15,00 (4,00-15,50)	15,00 (4,50-16,00)	15,00 (4,50-16,00)
Absorbed power - COOLING	nom (min-max)	kW	4,59 (1,00-6,50)	4,24 (1,00-6,00)	4,22 (1,00-6,00)
Absorbed power - HEATING	nom (min-max)	kW	4,37 (1,00-6,50)	4,04 (1,00-6,00)	4,02 (1,00-6,00)
Energy class	EER	W/W	2,92	3,21	3,22
	COP	W/W	3,43	3,71	3,73
COOLING Pdesign	35 °C	kW	13,40	13,60	13,60
HEATING Pdesign	(-10 °C)	kW	8,50	10	10
Energy class	SEER		5,98 (A+)	6,16 (A++)	6,18 (A++)
	SCOP		3,97 (A)	4,07 (A+)	4,10 (A+)
Annual Energy Consumption - COOLING		kWh/a	785	761	759
Annual Energy Consumption - HEATING		kWh/a	2998	3786	3754
Indoor Unit					
Power supply		Ph/V/Hz	1/220-240/50/60	1/220-240/50/60	1/220-240/50/60
Treated air volume	(H/M/L/Q)	m3/h	3600/3100/2600/2100	3600/3100/2600/2100	3600/3100/2600/2100
External static pressure		Pa	37/50(default)/70/90/110 /130/150/170/190/210	37/50(default)/70/90/110 /130/150/170/190/210	37/50(default)/70/90/110 /130/150/170/190/210
High sound power		dB	65	65	65
Sound pressure		dB(A)	49/46/43/40	49/46/43/40	49/46/43/40
Net dimensions	WxDxH	mm	1350x490x425	1350x490x425	1350x490x425
Packaging dimensions	WxDxH	mm	1565x724x510	1565x724x510	1565x724x510
Net/gross weight		kg	61,0/72,0	61,0/72,0	61,0/72,0
Outdoor Unit					
Power supply		Ph/V/Hz	3 /380-415/ 50/60	1/220-240/50/60	3/380-415/50/60
Power cable		N x mm2	5 x 4,0	3 x 6,0	5 x 4,0
Interconnection cable		N x mm2	4 x 2,5	4 x 2,5	4 x 2,5
Sound power	H	dB	72	70	70
Sound pressure	H	dB(A)	58	53	53
Running current cooling/heating	Max	A	10,0	32,0	10,0
Starting current cooling/heating	Max	A	2,0	6,0	2,0
Net dimensions	WxDxH	mm	950x370x965	950x370x1350	950x370x1350
Packaging dimensions	WxDxH	mm	1050x485x1130	1050x485x1500	1050x485x1500
Net/gross weight		kg	85,0/90,0	105,0/118,0	101,0/116,0
Compressor type			Twin rotary inverter	Twin rotary inverter	Twin rotary inverter
Installation data					
Refrigerant			R32	R32	R32
Liquid pipe	∅	mm (inch)	9,52 (3/8)	9,52 (3/8)	9,52 (3/8)
Gas pipe	∅	mm (inch)	15,88 (5/8)	15,88 (5/8)	15,88 (5/8)
Standard pipe length without refrigerant charge		m	30	30	30
Maximum pipe length		m	70	70	70
Maximum IU - OU elevation		m	30	30	30
Refrigerant charge in the factory		kg	2,30	2,90	3,50
Refrigerant charge in the factory		TCO2eq	1,55	1,96	2,36
Additional ref. charge over std length		g/m	45	45	45
Outdoor operating limits - COOLING	min-max	°C		-10-46	
Outdoor operating limits - HEATING	min-max	°C		-15-24	

Commercial R32 WALL MOUNTED



AS105S2SF2FA-2

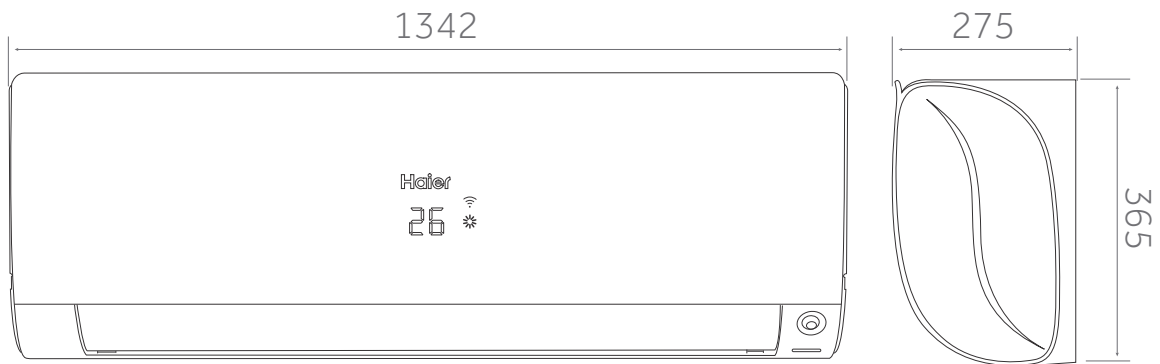

AS105S2SF2FA-2

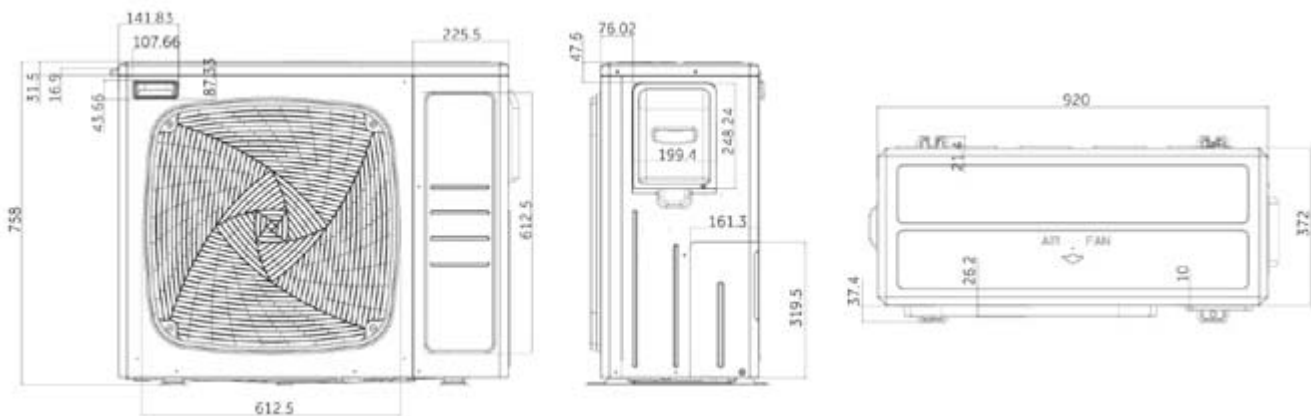

10,5 kW

Commercial R32 WALL MOUNTED

Haier

10,5 kW

COMMERCIAL R32



Standard YR-HE

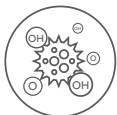

Nano-Aqua Sterilisation



Easy Installation



Wi-Fi Optional



Silence



Sleep

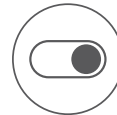

On-Off Card



3D

- Nano-Aqua Sterilisation
- Easy installation
- Wi-Fi control integrated
- Low noise level
- Comfortable Sleep
- On-Off Card
- 3D airflow: continuous movement of horizontal and vertical deflectors
- 2-Way Pipe Design

Indoor Unit	Model		AS105S2SF2FA-2
Outdoor Unit	Model		1U105S2SF2FA
Performance data			
Output power - COOLING	nom (min-max)	kW	9,00 (2,50-10,00)
Output power - HEATING	nom (min-max)	kW	9,50 (3,00-10,50)
Absorbed power - COOLING	nom (min-max)	kW	3,00 (0,80-3,70)
Absorbed power - HEATING	nom (min-max)	kW	2,56 (0,80-4,00)
Energy class	EER	W/W	3.00
	COP	W/W	3.71
COOLING Pdesign	35 °C	kW	9.00
HEATING Pdesign	(-10 °C)	kW	7.20
Energy class	SEER		6,10 (A++)
	SCOP		4,00 (A+)
Annual Energy Consumption - COOLING		kWh/a	516
Annual Energy Consumption - HEATING		kWh/a	2518
Indoor Unit			
Power supply		Ph/V/Hz	1/220-240/50/60
Treated air volume	Max	m ³ /h	1300
High sound power		dB	65
Sound pressure		dB(A)	48/44/40/36
Net dimensions	WxDxH	mm	1342x275x365
Packaging dimensions	WxDxH	mm	1418x402x478
Net/gross weight		kg	21,0/25,5
Outdoor Unit			
Power supply		Ph/V/Hz	1/220-240/50
Power cable		N x mm ²	3 x 4,0
Interconnection cable		N x mm ²	4 x 2,5
Sound power	H	dB	70
Sound pressure	H	dB(A)	60
Running current cooling/heating	Max	A	16.5
Starting current cooling/heating	Max	A	2,0
Compressor type			Twin rotary inverter
Packaging dimensions	WxDxH	mm	1050x485x1130
Net/gross weight		kg	85,0/90,0
Compressor type			Twin rotary inverter
Installation data			
Refrigerant			R32
Liquid pipe	∅	mm (inch)	9,52 (3/8)
Gas pipe	∅	mm (inch)	15,88 (5/8)
Standard pipe length without refrigerant charge		m	7
Maximum pipe length		m	50
Maximum IU - OU elevation		m	30
Refrigerant charge in the factory		kg	1.70
Refrigerant charge in the factory		TCO ₂ eq	1.15
Additional ref. charge over std length		g/m	45
Outdoor operating limits - COOLING	min-max	°C	-20-43
Outdoor operating limits - HEATING	min-max	°C	-20-24



AP140

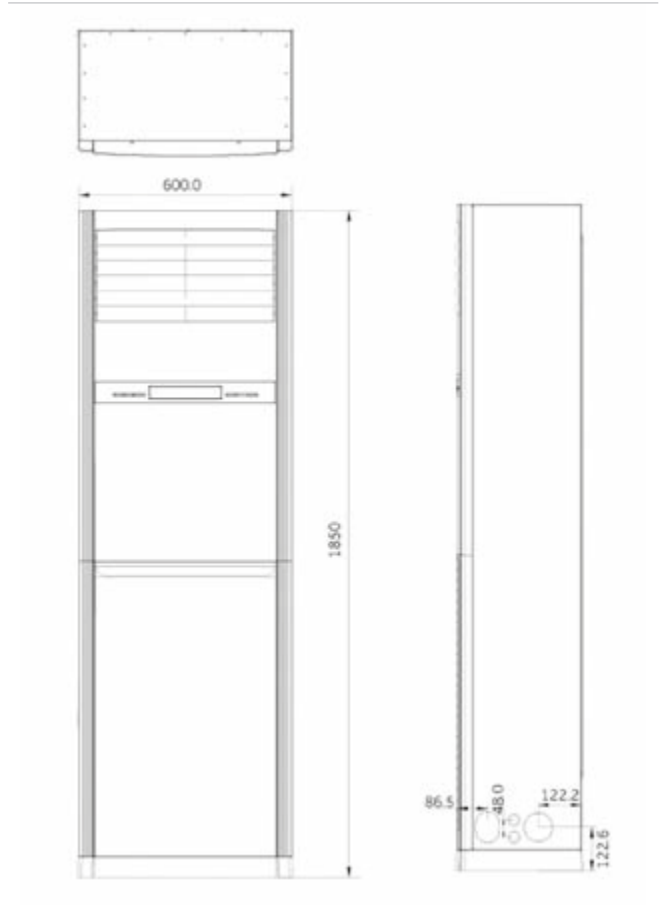

1U140

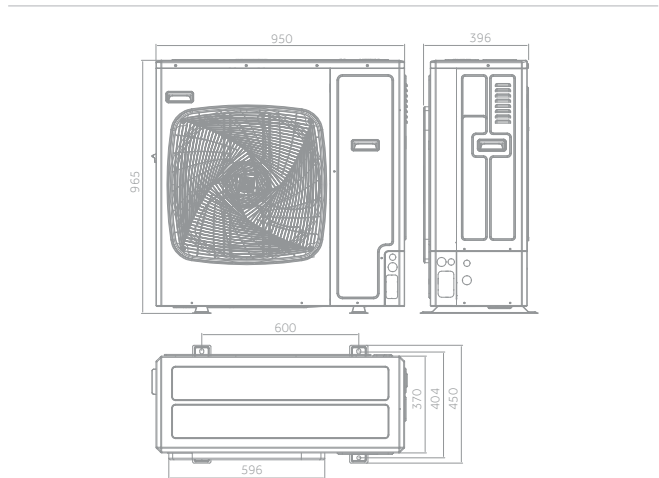

14,0 kW

Commercial R32 CABINET

Haier

14,0 kW

OPTIONAL CONTROL



YR-HRS01



Silence

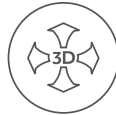

3D



Auto Mode



Auto Restart

- Low sound level
- 3D airflow: horizontal and vertical louver movement
- Auto mode
- Auto restart

Indoor Unit	Model		AP140S2SK1FA	AP140S2SK1FA
Outdoor Unit	Model		1U140S2SN1FA	1U140S2SN1FB
Performance data				
Output power - COOLING	nom (min-max)	kW	13,40 (3,50-14,00)	13,40 (3,50-14,00)
Output power - HEATING	nom (min-max)	kW	15,00 (4,00-15,50)	15,00 (4,00-15,50)
Absorbed power - COOLING	nom (min-max)	kW	5,83 (1,00-6,50)	5,40 (1,00-6,50)
Absorbed power - HEATING	nom (min-max)	kW	5,45 (1,00-6,50)	5,43 (1,00-6,50)
Energy class	EER	W/W	2,30	2,48
	COP	W/W	2,75	2,76
COOLING Pdesign	35 °C	kW	13,40	13,40
HEATING Pdesign	(-10 °C)	kW	8,50	8,50
Energy class	SEER		5,60 (A+)	5,66 (A+)
	SCOP		3,93 (A)	3,95 (A)
Annual Energy Consumption - COOLING		kWh/a	837	829
Annual Energy Consumption - HEATING		kWh/a	3018	3012
Indoor Unit				
Power supply		Ph/V/Hz	1/220-240/50/60	1/220-240/50/60
Treated air volume	(H/M/L/Q)	m ³ /h	1850/1500/1350	1850/1500/1350
High sound power		dB	65	65
Sound pressure		dB(A)	52/49/46	52/49/46
Net dimensions	WxDxH	mm	600x350x1850	600x350x1850
Packaging dimensions	WxDxH	mm	693x438x2035	693x438x2035
Net/gross weight		kg	61,0/50,0	61,0/50,0
Outdoor Unit				
Power supply		Ph/V/Hz	1 / 220-240/ 50/60	3 / 380-415/ 50/60
Power cable		N x mm ²	3 x 6,0	5 x 4,0
Interconnection cable		N x mm ²	4 x 2,5	4 x 2,5
Sound power	H	dB	72	72
Sound pressure	H	dB(A)	58	58
Running current cooling/heating	Max	A	30,0	10,0
Starting current cooling/heating	Max	A	5,0	2,0
Net dimensions	WxDxH	mm	950x370x965	950x370x965
Packaging dimensions	WxDxH	mm	1050x485x1130	1050x485x1130
Net/gross weight		kg	84,0/89,0	85,0/90,0
Compressor type			Twin rotary inverter	Twin rotary inverter
Installation data				
Refrigerant			R32	R32
Liquid pipe	∅	mm (inch)	9,52 (3/8)	9,52 (3/8)
Gas pipe	∅	mm (inch)	15,88 (5/8)	15,88 (5/8)
Standard pipe length without refrigerant charge		m	10	10
Maximum pipe length		m	70	70
Maximum IU - OU elevation		m	30	30
Refrigerant charge in the factory		kg	2,30	2,30
Refrigerant charge in the factory		TCO ₂ eq	1,55	1,55
Additional ref. charge over std length		g/m	45	45
Outdoor operating limits - COOLING	min-max	°C		-10-46
Outdoor operating limits - HEATING	min-max	°C		-15-24



AP140

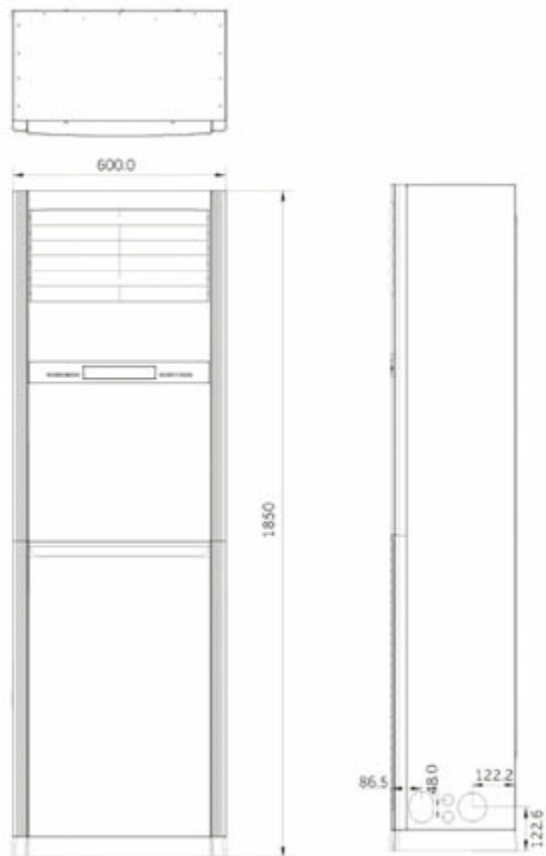

1U140

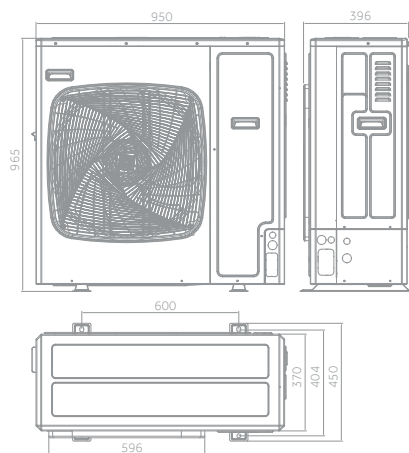

14,0 kW

Commercial R32 CABINET **NEW**

Haier

14,0 kW

OPTIONAL CONTROL



YR-HRS01



Silence



3D



Auto Mode



Auto Restart



Wi-Fi Optional



UVC Sterilisation









NEW

- Low sound level
- 3D airflow: horizontal and vertical louver movement
- Auto mode
- Auto restart
- Wi-Fi control integrated
- UVC Sterilisation

Indoor Unit	Model		AP140S2SK1FA(H)	AP140S2SK1FA(H)
Outdoor Unit	Model		1U140S2SN1FA	1U140S2SN1FB
Performance data				
Output power - COOLING	nom (min-max)	kW	13,40 (3,50-14,00)	13,40 (3,50-14,00)
Output power - HEATING	nom (min-max)	kW	15,00 (4,00-15,50)	15,00 (4,00-15,50)
Absorbed power - COOLING	nom (min-max)	kW	5,83 (1,00-6,50)	5,40 (1,00-6,50)
Absorbed power - HEATING	nom (min-max)	kW	5,45 (1,00-6,50)	5,43 (1,00-6,50)
Energy class	EER	W/W	2,30	2,48
	COP	W/W	2,75	2,76
COOLING Pdesign	35 °C	kW	13,40	13,40
HEATING Pdesign	(-10 °C)	kW	8,50	8,50
Energy class	SEER		5,60 (A+)	5,66 (A+)
	SCOP		3,93 (A)	3,95 (A)
Annual Energy Consumption - COOLING		kWh/a	837	829
Annual Energy Consumption - HEATING		kWh/a	3018	3012
Indoor Unit				
Power supply		Ph/V/Hz	1/220-240/50/60	1/220-240/50/60
Treated air volume	(H/M/L/Q)	m ³ /h	1850/1500/1350	1850/1500/1350
High sound power		dB	65	65
Sound pressure		dB(A)	52/49/46	52/49/46
Net dimensions	WxDxH	mm	600x350x1850	600x350x1850
Packaging dimensions	WxDxH	mm	693x438x2035	693x438x2035
Net/gross weight		kg	61,0/50,0	61,0/50,0
Outdoor Unit				
Power supply		Ph/V/Hz	1 / 220-240/ 50/60	3 / 380-415/ 50/60
Power cable		N x mm ²	3 x 6,0	5 x 4,0
Interconnection cable		N x mm ²	4 x 2,5	4 x 2,5
Sound power	H	dB	72	72
Sound pressure	H	dB(A)	58	58
Running current cooling/heating	Max	A	30,0	10,0
Starting current cooling/heating	Max	A	5,0	2,0
Net dimensions	WxDxH	mm	950x370x965	950x370x965
Packaging dimensions	WxDxH	mm	1050x485x1130	1050x485x1130
Net/gross weight		kg	84,0/89,0	85,0/90,0
Compressor type			Twin rotary inverter	Twin rotary inverter
Installation data				
Refrigerant			R32	R32
Liquid pipe	∅	mm (inch)	9,52 (3/8)	9,52 (3/8)
Gas pipe	∅	mm (inch)	15,88 (5/8)	15,88 (5/8)
Standard pipe length without refrigerant charge		m	10	10
Maximum pipe length		m	70	70
Maximum IU - OU elevation		m	30	30
Refrigerant charge in the factory		kg	2,30	2,30
Refrigerant charge in the factory		TCO ₂ eq	1,55	1,55
Additional ref. charge over std length		g/m	45	45
Outdoor operating limits - COOLING	min-max	°C		-10-46
Outdoor operating limits - HEATING	min-max	°C		-15-24

MAXI SPLIT R32



INDOOR UNITS		CASSETTE			CEILING FLOOR		
							
OUTDOOR UNITS		1:2	1:3	1:4	1:2	1:3	1:4
10,5 kW		AB50S2SC2FA / AB50S2SC2FA-1 AB50S2SC2FA / AB50S2SC2FA-1 AB50S2SC2FA / AB50S2SC2FA-1	AB35S2SC2FA / AB35S2SC2FA-1 AB35S2SC2FA / AB35S2SC2FA-1 AB35S2SC2FA / AB35S2SC2FA-1 AB35S2SC2FA / AB35S2SC2FA-1 AB35S2SC2FA / AB35S2SC2FA-1	AB25S2SC2FA / AB25S2SC2FA-1 AB25S2SC2FA / AB25S2SC2FA-1 AB25S2SC2FA / AB25S2SC2FA-1 AB25S2SC2FA / AB25S2SC2FA-1 AB25S2SC2FA / AB25S2SC2FA-1 AB25S2SC2FA / AB25S2SC2FA-1	AC50S2SG1FA AC50S2SG1FA	AC35S2SG1FA AC35S2SG1FA AC35S2SG1FA	
	SINGLE-PHASE	1U10S2SS2FA	JOINT KIT FQG-2Y100A	JOINT KIT FQG-3Y200A + ADAPTER	JOINT KIT FQG-4Y200A + ADAPTER	JOINT KIT FQG-2Y100A	JOINT KIT FQG-3Y200A + ADAPTER
THREE-PHASE	1U10S2SS1FB						
12,5 kW		AB71S2SG1FA AB71S2SG1FA	AB50S2SC2FA / AB50S2SC2FA-1 AB50S2SC2FA / AB50S2SC2FA-1 AB50S2SC2FA / AB50S2SC2FA-1 AB50S2SC2FA / AB50S2SC2FA-1 AB50S2SC2FA / AB50S2SC2FA-1	AB35S2SC2FA / AB35S2SC2FA-1 AB35S2SC2FA / AB35S2SC2FA-1 AB35S2SC2FA / AB35S2SC2FA-1 AB35S2SC2FA / AB35S2SC2FA-1 AB35S2SC2FA / AB35S2SC2FA-1 AB35S2SC2FA / AB35S2SC2FA-1	AC71S2SG1FA AC71S2SG1FA	AC50S2SG1FA AC50S2SG1FA AC50S2SG1FA	AC35S2SG1FA AC35S2SG1FA AC35S2SG1FA AC35S2SG1FA
	SINGLE-PHASE	1U12S2SN2FA	JOINT KIT FQG-2Y200A + ADAPTER	JOINT KIT FQG-3Y200A + ADAPTER	JOINT KIT FQG-4Y200A + ADAPTER	JOINT KIT FQG-2Y200A + ADAPTER	JOINT KIT FQG-3Y200A + ADAPTER
THREE-PHASE	1U12S2SN2FB						
14,0 kW	NEW 	AB71S2SG1FA AB71S2SG1FA	AB50S2SC2FA / AB50S2SC2FA-1 AB50S2SC2FA / AB50S2SC2FA-1 AB50S2SC2FA / AB50S2SC2FA-1 AB50S2SC2FA / AB50S2SC2FA-1 AB50S2SC2FA / AB50S2SC2FA-1	AB35S2SC2FA / AB35S2SC2FA-1 AB35S2SC2FA / AB35S2SC2FA-1 AB35S2SC2FA / AB35S2SC2FA-1 AB35S2SC2FA / AB35S2SC2FA-1 AB35S2SC2FA / AB35S2SC2FA-1 AB35S2SC2FA / AB35S2SC2FA-1	AC71S2SG1FA AC71S2SG1FA	AC50S2SG1FA AC50S2SG1FA AC50S2SG1FA	AC35S2SG1FA AC35S2SG1FA AC35S2SG1FA AC35S2SG1FA
	SINGLE-PHASE	1U140S2SN1FA	JOINT KIT FQG-2Y200A + ADAPTER	JOINT KIT FQG-3Y200A + ADAPTER	JOINT KIT FQG-4Y200A + ADAPTER	JOINT KIT FQG-2Y200A + ADAPTER	JOINT KIT FQG-3Y200A + ADAPTER
THREE-PHASE	1U140S2SN1FB						
16,0 kW	NEW 	AB71S2SG1FA AB71S2SG1FA	AB50S2SC2FA / AB50S2SC2FA-1 AB50S2SC2FA / AB50S2SC2FA-1 AB50S2SC2FA / AB50S2SC2FA-1 AB50S2SC2FA / AB50S2SC2FA-1 AB50S2SC2FA / AB50S2SC2FA-1	AB35S2SC2FA / AB35S2SC2FA-1 AB35S2SC2FA / AB35S2SC2FA-1 AB35S2SC2FA / AB35S2SC2FA-1 AB35S2SC2FA / AB35S2SC2FA-1 AB35S2SC2FA / AB35S2SC2FA-1 AB35S2SC2FA / AB35S2SC2FA-1	AC71S2SG1FA AC71S2SG1FA	AC50S2SG1FA AC50S2SG1FA AC50S2SG1FA	AC35S2SG1FA AC35S2SG1FA AC35S2SG1FA AC35S2SG1FA
	THREE-PHASE	1U160S2SP1FB	JOINT KIT FQG-2Y200A + ADAPTER	JOINT KIT FQG-3Y200A + ADAPTER	JOINT KIT FQG-4Y200A + ADAPTER	JOINT KIT FQG-2Y200A + ADAPTER	JOINT KIT FQG-3Y200A + ADAPTER
CONTROLLERS AND ACCESSORIES		WIRED CONTROLLERS (REQUIRED FOR SYSTEM)					
		OPTIONAL					
			YR-E17A		YR-E16B		

Range R32 SUPER MATCH MultiSplit Inverter





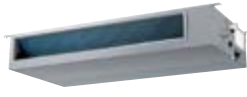





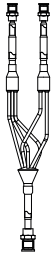

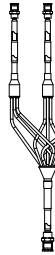
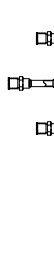

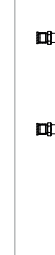
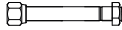
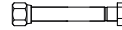
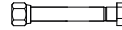

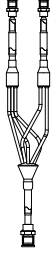

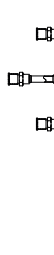

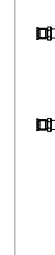
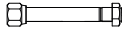
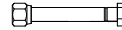
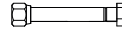

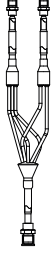

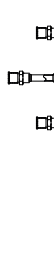
Haier

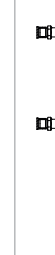
MAXI SPLIT R32

SLIM DUCT LOW PRESSURE			DUCTED MEDIUM PRESSURE		
					
1:2	1:3	1:4	1:2	1:3	1:4
AD50S2SS1FA / AD50S2SS1FA(H) AD50S2SS1FA / AD50S2SS1FA(H) AD50S2SS1FA / AD50S2SS1FA(H)	AD35S2SS1FA / AD35S2SS1FA(H) AD35S2SS1FA / AD35S2SS1FA(H) AD35S2SS1FA / AD35S2SS1FA(H) AD35S2SS1FA / AD35S2SS1FA(H) AD35S2SS1FA / AD35S2SS1FA(H) AD35S2SS1FA / AD35S2SS1FA(H)	AD25S2SS1FA AD25S2SS1FA AD25S2SS1FA	AD50S2SM3FA / AD50S2SM3FA(H) AD50S2SM3FA / AD50S2SM3FA(H) AD50S2SM3FA / AD50S2SM3FA(H)	AD35S2SM3FA / AD35S2SM3FA(H) AD35S2SM3FA / AD35S2SM3FA(H) AD35S2SM3FA / AD35S2SM3FA(H) AD35S2SM3FA / AD35S2SM3FA(H) AD35S2SM3FA / AD35S2SM3FA(H)	
JOINT KIT FQG-2Y100A	JOINT KIT FQG-3Y200A + ADAPTER		JOINT KIT FQG-2Y100A	JOINT KIT FQG-3Y200A + ADAPTER	
AD71S2SS1FA / AD71S2SS1FA(H) AD71S2SS1FA / AD71S2SS1FA(H) AD71S2SS1FA / AD71S2SS1FA(H)	AD50S2SS1FA / AD50S2SS1FA(H) AD50S2SS1FA / AD50S2SS1FA(H) AD50S2SS1FA / AD50S2SS1FA(H) AD50S2SS1FA / AD50S2SS1FA(H) AD50S2SS1FA / AD50S2SS1FA(H)	AD35S2SS1FA / AD35S2SS1FA(H) AD35S2SS1FA / AD35S2SS1FA(H) AD35S2SS1FA / AD35S2SS1FA(H) AD35S2SS1FA / AD35S2SS1FA(H) AD35S2SS1FA / AD35S2SS1FA(H) AD35S2SS1FA / AD35S2SS1FA(H)	AD71S2SM3FA / AD71S2SM3FA(H) AD71S2SM3FA / AD71S2SM3FA(H) AD71S2SM3FA / AD71S2SM3FA(H)	AD50S2SM3FA / AD50S2SM3FA(H) AD50S2SM3FA / AD50S2SM3FA(H) AD50S2SM3FA / AD50S2SM3FA(H) AD50S2SM3FA / AD50S2SM3FA(H) AD50S2SM3FA / AD50S2SM3FA(H)	AD35S2SM3FA / AD35S2SM3FA(H) AD35S2SM3FA / AD35S2SM3FA(H) AD35S2SM3FA / AD35S2SM3FA(H) AD35S2SM3FA / AD35S2SM3FA(H) AD35S2SM3FA / AD35S2SM3FA(H) AD35S2SM3FA / AD35S2SM3FA(H)
JOINT KIT FQG-2Y200A + ADAPTER	JOINT KIT FQG-3Y200A + ADAPTER	JOINT KIT FQG-4Y200A + ADAPTER	JOINT KIT FQG-2Y200A + ADAPTER	JOINT KIT FQG-3Y200A + ADAPTER	JOINT KIT FQG-4Y200A + ADAPTER
AD71S2SS1FA / AD71S2SS1FA(H) AD71S2SS1FA / AD71S2SS1FA(H) AD71S2SS1FA / AD71S2SS1FA(H)	AD50S2SS1FA / AD50S2SS1FA(H) AD50S2SS1FA / AD50S2SS1FA(H) AD50S2SS1FA / AD50S2SS1FA(H) AD50S2SS1FA / AD50S2SS1FA(H) AD50S2SS1FA / AD50S2SS1FA(H)	AD35S2SS1FA / AD35S2SS1FA(H) AD35S2SS1FA / AD35S2SS1FA(H) AD35S2SS1FA / AD35S2SS1FA(H) AD35S2SS1FA / AD35S2SS1FA(H) AD35S2SS1FA / AD35S2SS1FA(H) AD35S2SS1FA / AD35S2SS1FA(H)	AD71S2SM3FA / AD71S2SM3FA(H) AD71S2SM3FA / AD71S2SM3FA(H) AD71S2SM3FA / AD71S2SM3FA(H)	AD50S2SM3FA / AD50S2SM3FA(H) AD50S2SM3FA / AD50S2SM3FA(H) AD50S2SM3FA / AD50S2SM3FA(H)	AD35S2SM3FA / AD35S2SM3FA(H) AD35S2SM3FA / AD35S2SM3FA(H) AD35S2SM3FA / AD35S2SM3FA(H) AD35S2SM3FA / AD35S2SM3FA(H) AD35S2SM3FA / AD35S2SM3FA(H) AD35S2SM3FA / AD35S2SM3FA(H)
JOINT KIT FQG-2Y200A + ADAPTER	JOINT KIT FQG-3Y200A + ADAPTER	JOINT KIT FQG-4Y200A + ADAPTER	JOINT KIT FQG-2Y200A + ADAPTER	JOINT KIT FQG-3Y200A + ADAPTER	JOINT KIT FQG-4Y200A + ADAPTER
AD71S2SS1FA / AD71S2SS1FA(H) AD71S2SS1FA / AD71S2SS1FA(H) AD71S2SS1FA / AD71S2SS1FA(H)	AD50S2SS1FA / AD50S2SS1FA(H) AD50S2SS1FA / AD50S2SS1FA(H) AD50S2SS1FA / AD50S2SS1FA(H) AD50S2SS1FA / AD50S2SS1FA(H) AD50S2SS1FA / AD50S2SS1FA(H)	AD35S2SS1FA / AD35S2SS1FA(H) AD35S2SS1FA / AD35S2SS1FA(H) AD35S2SS1FA / AD35S2SS1FA(H) AD35S2SS1FA / AD35S2SS1FA(H) AD35S2SS1FA / AD35S2SS1FA(H) AD35S2SS1FA / AD35S2SS1FA(H)	AD71S2SM3FA / AD71S2SM3FA(H) AD71S2SM3FA / AD71S2SM3FA(H) AD71S2SM3FA / AD71S2SM3FA(H)	AD50S2SM3FA / AD50S2SM3FA(H) AD50S2SM3FA / AD50S2SM3FA(H) AD50S2SM3FA / AD50S2SM3FA(H) AD50S2SM3FA / AD50S2SM3FA(H) AD50S2SM3FA / AD50S2SM3FA(H)	AD35S2SM3FA / AD35S2SM3FA(H) AD35S2SM3FA / AD35S2SM3FA(H) AD35S2SM3FA / AD35S2SM3FA(H) AD35S2SM3FA / AD35S2SM3FA(H) AD35S2SM3FA / AD35S2SM3FA(H) AD35S2SM3FA / AD35S2SM3FA(H)
JOINT KIT FQG-2Y200A + ADAPTER	JOINT KIT FQG-3Y200A + ADAPTER	JOINT KIT FQG-4Y200A + ADAPTER	JOINT KIT FQG-2Y200A + ADAPTER	JOINT KIT FQG-3Y200A + ADAPTER	JOINT KIT FQG-4Y200A + ADAPTER

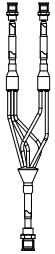
CENTRAL CONTROLLERS		BMS	WI-FI	
				
HC-SA164DBT	YCZ-A004	HCM-05A	KZW-W001	HI-WB201DEI

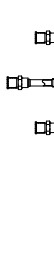
The data in this catalogue is purely indicative as the data may vary. Please be advised to check the accuracy of the data with the supplier before purchasing products.

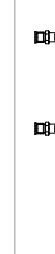
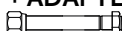
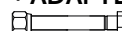
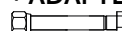
OUTDOOR UNITS		1:2		1:3		1:4		
10,5 kW								
			LIQUID	GAS	LIQUID	GAS	LIQUID	GAS
SINGLE-PHASE	1U105S2SS2FA		JOINT KIT FQG-2Y100A + ADAPTER 		JOINT KIT FQG-3Y200A + ADAPTER 		JOINT KIT FQG-4Y200A + ADAPTER 	
THREE-PHASE	1U105S2SS1FB							
12,5 kW								
			LIQUID	GAS	LIQUID	GAS	LIQUID	GAS
SINGLE-PHASE	1U125S2SN2FA		JOINT KIT FQG-2Y200A + ADAPTER 		JOINT KIT FQG-3Y200A + ADAPTER 		JOINT KIT FQG-4Y200A + ADAPTER 	
THREE-PHASE	1U125S2SN2FB							
14,0 kW	NEW  							
			LIQUID	GAS	LIQUID	GAS	LIQUID	GAS
SINGLE-PHASE	1U140S2SN1FA	1U140S2SP2FA	JOINT KIT FQG-2Y200A + ADAPTER 		JOINT KIT FQG-3Y200A + ADAPTER 		JOINT KIT FQG-4Y200A + ADAPTER 	
THREE-PHASE	1U140S2SN1FB	1U140S2SP2FB						
16,0 kW	NEW 							
			LIQUID	GAS	LIQUID	GAS	LIQUID	GAS
THREE-PHASE	1U160S2SP1FB		JOINT KIT FQG-2Y200A + ADAPTER 		JOINT KIT FQG-3Y200A + ADAPTER 		JOINT KIT FQG-4Y200A + ADAPTER 	

SPECIFICATIONS

EXTERNAL UNIT	INTERNAL UNIT	UNIT N° INTERNAL	COMMAND WIRE	GAS	LIQUID	JOINT
1U105S2SS2FA 1U105S2SS1FB	AB50S2SC1FA / AB50S2SC1FA-1 AC50S2SG1FA AD50S2SS1FA / AD50S2SS1FA-1 AD50S2SM3FA / AD50S2SM3FA	2	YR-E17			FQG-2Y100A
1U125S2SN2FA 1U125S2SN2FB 1U140S2SN1FA 1U140S2SN1FB 1U140S2SP2FA 1U140S2SP2FB 1U160S2SP1FB	AB71S2SG1FA AC71S2SG1FA AD71S2SS1FA / AD71S2SS1FA-1 AD71S2SM3FA / AD71S2SM3FA-1	2	YR-E17			FQG-2Y200A
1U105S2SS2FA 1U105S2SS1FB	AB35S2SG1FA AC35S2SG1FA AD35S2SS1FA / AD35S2SS1FA-1 AD35S2SM3FA / AD35S2SM3FA-1	3	YR-E17			FQG-3Y100A
1U125S2SN2FA 1U125S2SN2FB 1U140S2SN1FA 1U140S2SN1FB 1U140S2SP2FA 1U140S2SP2FB 1U160S2SP1FB	AB50S2SC1FA / AB50S2SC1FA-1 AC50S2SG1FA AD50S2SS1FA / AD50S2SS1FA(H) AD50S2SM3FA / AD50S2SM3FA(H)	3	YR-E17			FQG-3Y200A
1U105S2SS2FA 1U105S2SS1FB 1U125S2SN2FA 1U125S2SN2FB 1U140S2SN1FA 1U140S2SN1FB 1U140S2SP2FA 1U140S2SP2FB 1U160S2SP1FB	AB25S2SC2FA / AB25S2SC2FA-1 AB35S2SC1FA / AB35S2SC1FA-1 AC35S2SG1FA AD25S2SS1FA / AD35S2SS1FA / AD35S2SS1FA(H) AD35S2SM3FA / AD35S2SM3FA(H)	4	YR-E17			FQG-4Y200A

PIPE SPECIFICATIONS

N° UI	Pipe diagram	Max pipe length (m)			Max altitude difference UE - UI (m)			Max length single UI (m)			Max altitude difference UI - UI (m)			Max difference pipe length (m)			Pipe diameter (mm)			Joint diameter (mm)		
		L+L1+L2			H			L1 o L2			H1			L1 - L2			liquid / gas			liquid / gas		
2		1U	1U	1U	1U	1U	1U	1U	1U	1U	1U	1U	1U	1U	1U	1U	1U	1U	1U	1U	1U	1U
		105	125	140	105	125	140	105	125	140	105	125	140	105	125	140	105	125	140	105	125	140
		≤50	≤50	≤75	≤30	≤30	≤30	≤20			≤0,5			≤10			9,52	9,52	9,52	9,52	9,52	9,52
																	15,88	15,88	15,88	6,35	6,35	6,35
3		1U	1U	1U	1U	1U	1U	1U	1U	1U	1U	1U	1U	1U	1U	1U	1U	1U	1U	1U	1U	1U
		105	125	140	105	125	140	105	125	140	105	125	140	105	125	140	105	125	140	105	125	140
		≤50	≤60	≤75	≤20	≤30	≤30	≤20			≤0,5			≤10			9,52	9,52	9,52	6,35	6,35	6,35
																	15,88	15,88	15,88	9,52	12,7	12,7
4		1U	1U	1U	1U	1U	1U	1U	1U	1U	1U	1U	1U	1U	1U	1U	1U	1U	1U	1U	1U	1U
		105	125	140	105	125	140	105	125	140	105	125	140	105	125	140	105	125	140	105	125	140
		≤50	≤60	≤75	≤20	≤30	≤30	≤20	≤20	≤20	≤0,5	≤0,5	≤0,5	≤10			9,52	9,52	9,52	6,35	6,35	6,35
																	15,88	15,88	15,88	12,7	9,52	9,52

The MAXI SPLIT system is designed to ensure better air distribution.

The use of a practical collector enables the connection of up to 4 internal units (of the same type), running simultaneously to one external unit (mono).

